



US009406477B2

(12) **United States Patent**
Tarhani et al.

(10) **Patent No.:** **US 9,406,477 B2**
(45) **Date of Patent:** **Aug. 2, 2016**

(54) **TRAVELING WAVE TUBE LOADED BY A MATERIAL HAVING NEGATIVE PERMITTIVITY AND POSITIVE PERMEABILITY**

USPC 315/3.5
See application file for complete search history.

(56) **References Cited**

U.S. PATENT DOCUMENTS

7,218,190 B2 5/2007 Engheta et al.
7,429,957 B1 9/2008 Tonn
8,593,355 B1 11/2013 Tonn

OTHER PUBLICATIONS

Bhattacharjee et al., *Folded Waveguide Traveling-Wave Tube Sources for Terahertz Radiation*, IEEE Transactions on Plasma Science, vol. 32, No. 3, Jun. 2004, pp. 1002-1014.
Booske et al., *Accurate Parametric Modeling of Folded Waveguide Circuits for Millimeter-Wave Traveling Wave Tubes*, IEEE Transactions on Electron Devices, vol. 52, No. 5, May 2005, pp. 685-694.
Tan et al., *Wave Energy Amplification in a Metamaterial based Traveling Wave Structure*, physics.optics, Cornell University Library, arXiv:1003.5401v1, Mar. 28, 2010, pp. 1-4.
Shin et al., *MEMS fabrications of broadband epsilon negative (ENG) metamaterial electronic circuit for 0.22 THz sheet beam TWT application*, Downloaded from <http://ieeexplore.ieee.org/xpl/login.jsp?reload=true&tp=&arnumber=5612550&url=http%3A%2F%2Fiee> on Feb. 18, 2014, pp. 1-2.

(71) Applicant: **Wisconsin Alumni Research Foundation**, Madison, WI (US)

(72) Inventors: **Arash Rashidi Tarhani**, Madison, WI (US); **Nader Behdad**, Madison, WI (US)

(73) Assignee: **Wisconsin Alumni Research Foundation**, Madison, WI (US)

(*) Notice: Subject to any disclaimer, the term of this patent is extended or adjusted under 35 U.S.C. 154(b) by 0 days.

(21) Appl. No.: **14/202,992**

(22) Filed: **Mar. 10, 2014**

(65) **Prior Publication Data**

US 2015/0256139 A1 Sep. 10, 2015

(51) **Int. Cl.**

H01J 25/34 (2006.01)
H03F 3/58 (2006.01)
H01J 23/24 (2006.01)
H01J 23/30 (2006.01)
H01J 25/38 (2006.01)
H01P 3/123 (2006.01)

(52) **U.S. Cl.**

CPC **H01J 25/34** (2013.01); **H01J 23/24** (2013.01); **H01J 23/30** (2013.01); **H01J 25/38** (2013.01); **H03F 3/58** (2013.01); **H01P 3/123** (2013.01); **H03F 2200/451** (2013.01)

(58) **Field of Classification Search**

CPC H01J 23/24; H01J 23/30; H01J 25/34

Primary Examiner — Benny Lee

(74) *Attorney, Agent, or Firm* — Bell & Manning, LLC

(57) **ABSTRACT**

A slow wave structure of a traveling wave tube is provided. The slow wave structure includes an input port, an output port, a first material, and a second material. The second material is mounted in the first material at periodic intervals in a direction of propagation of a radio frequency signal between the input port and the output port. The second material has a real part of permittivity that is negative and a real part of permeability that is positive at an operational frequency of the radio frequency signal.

20 Claims, 14 Drawing Sheets

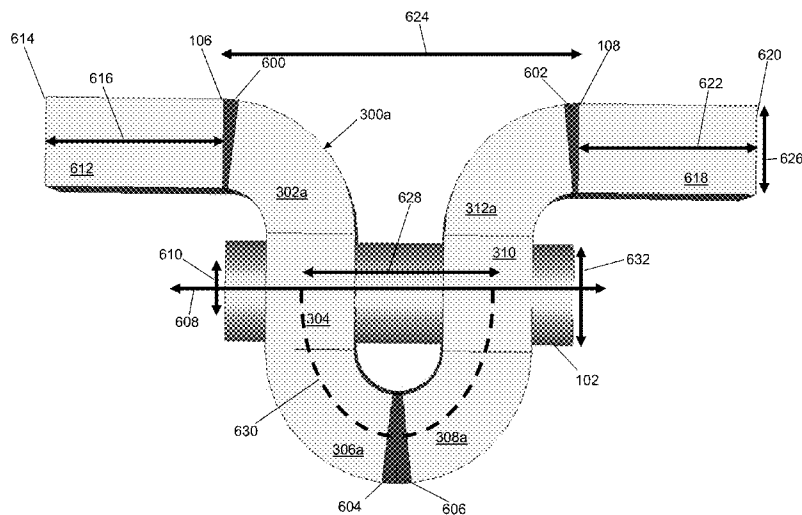

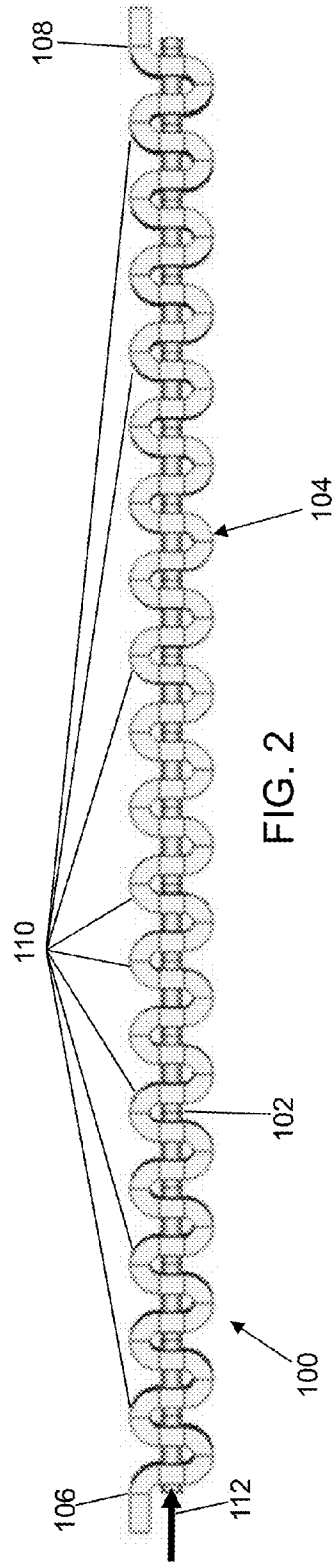
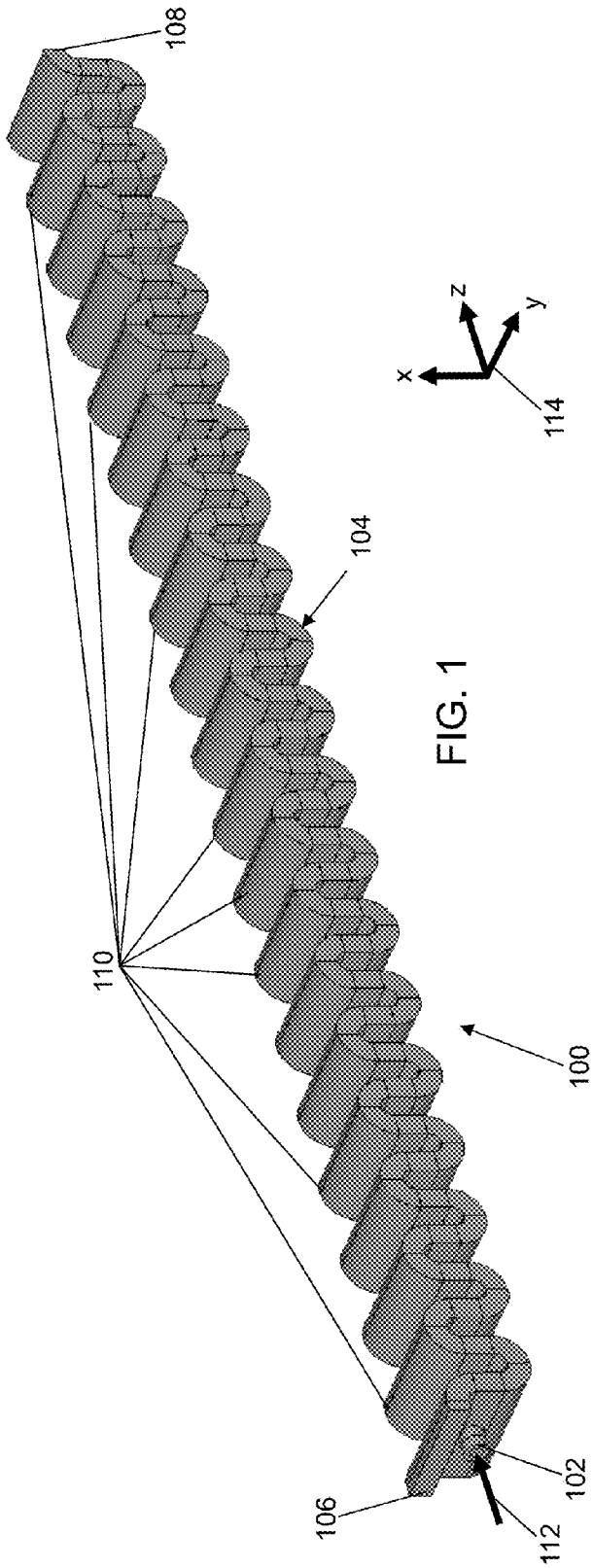

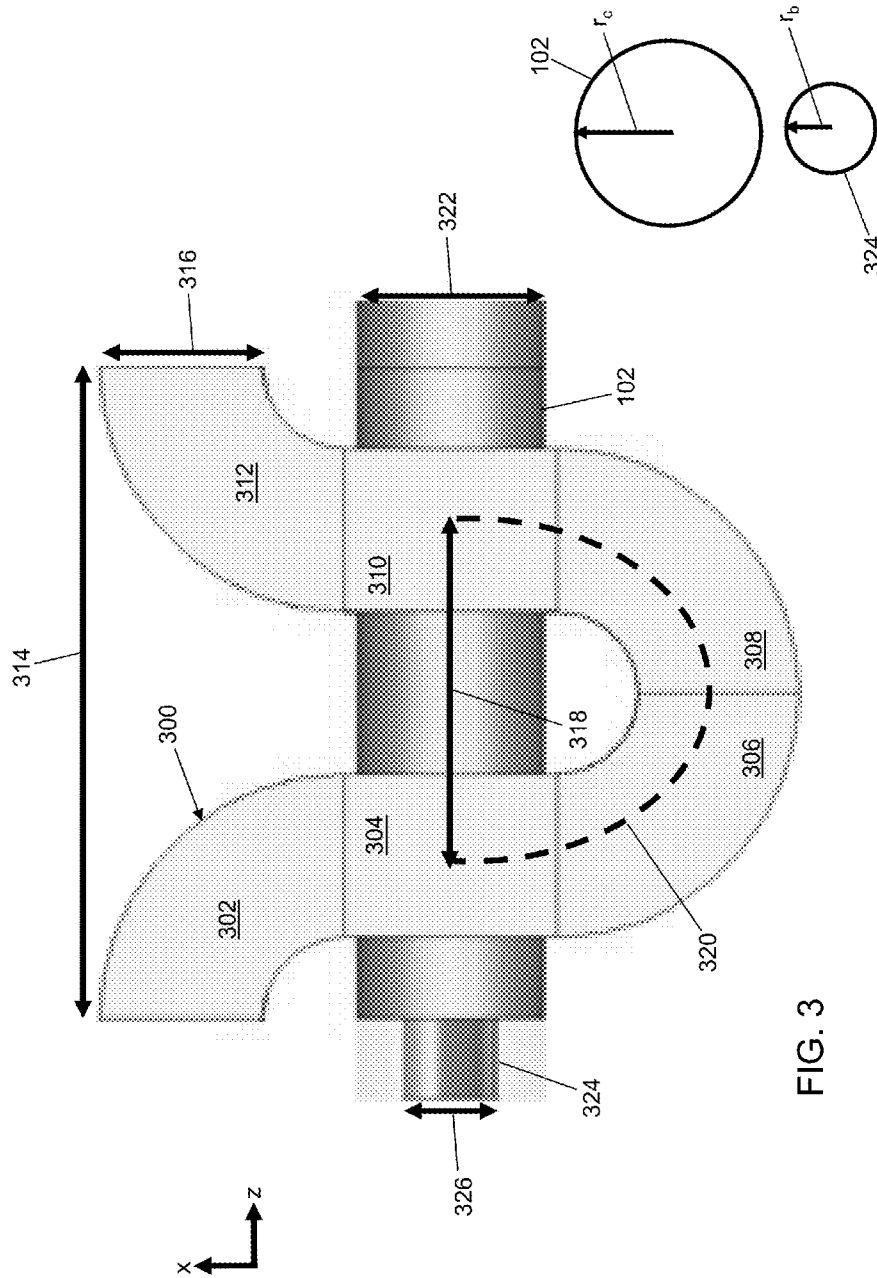

FIG. 3

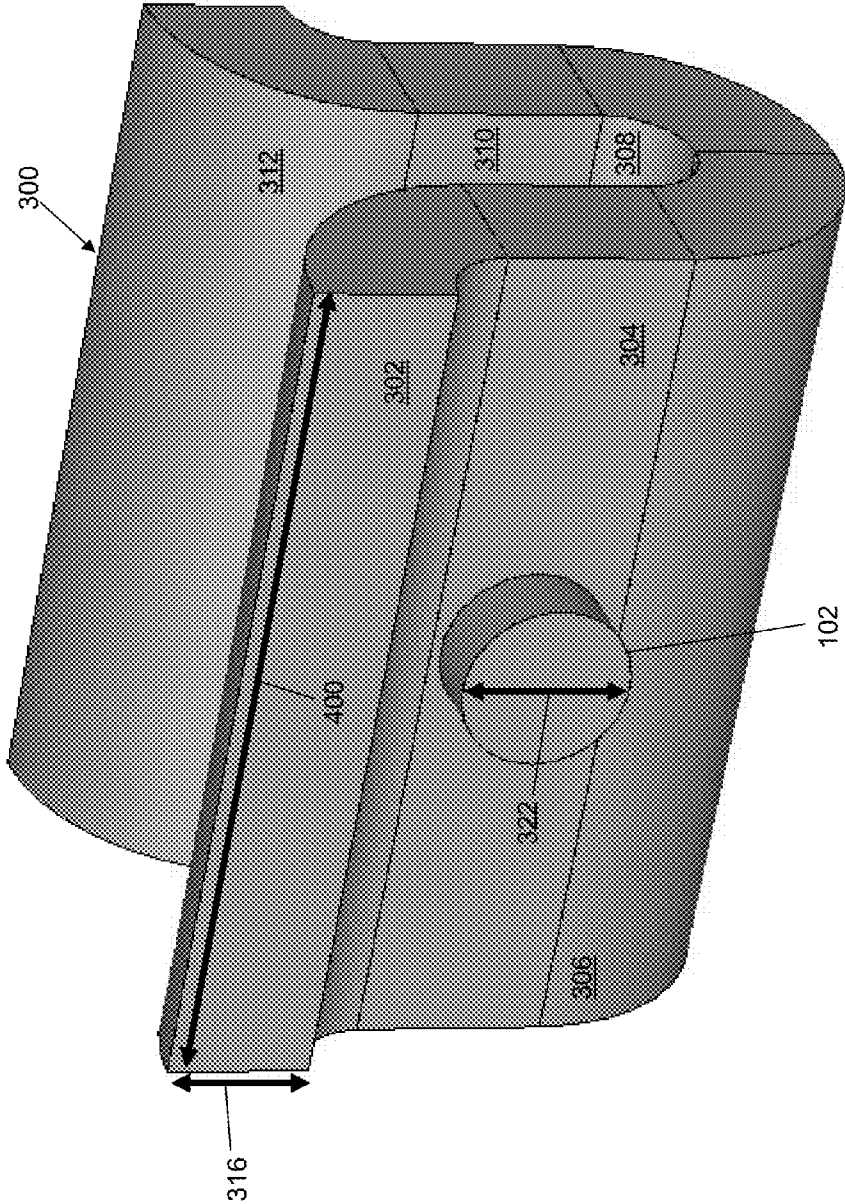

FIG. 4

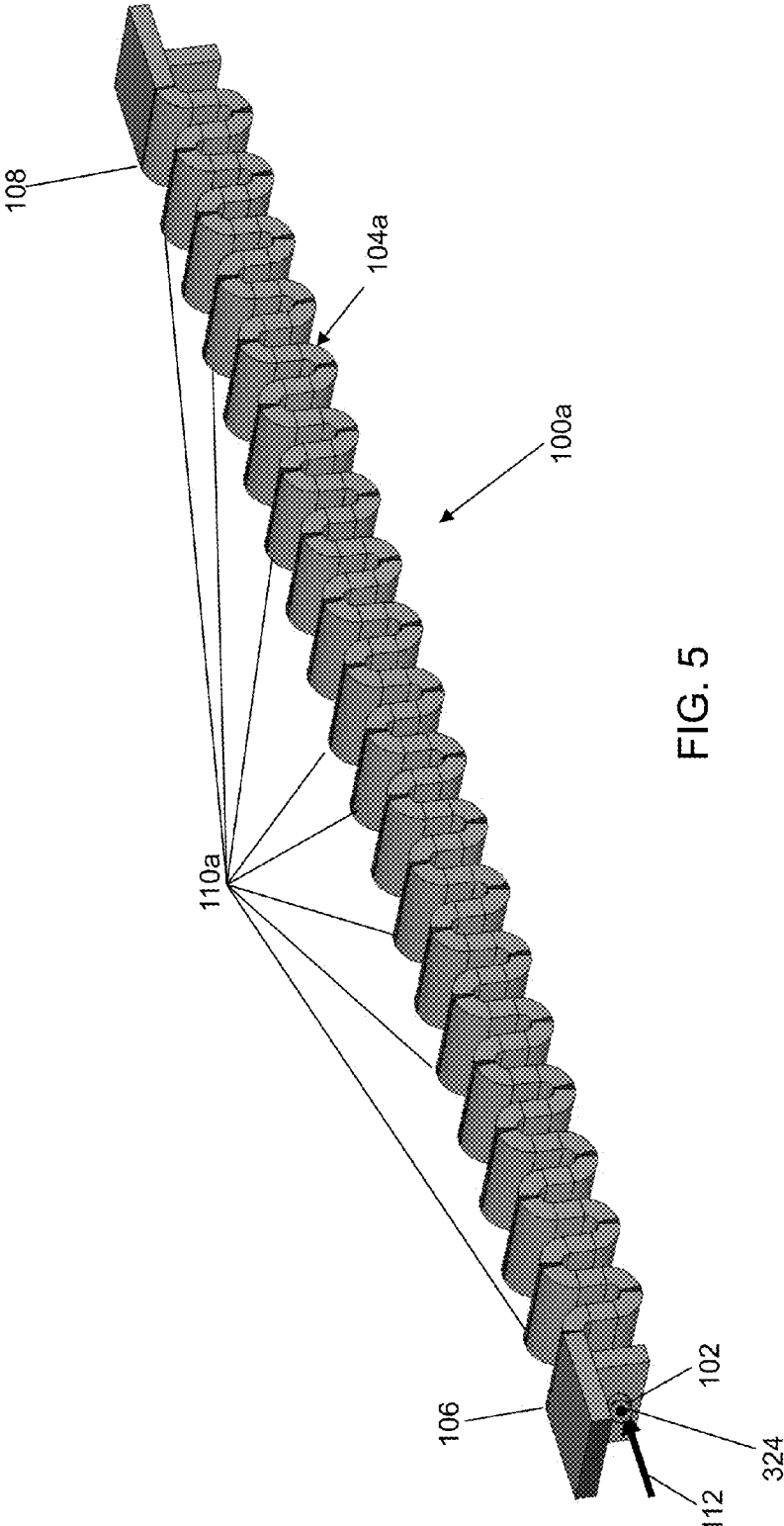

FIG. 5

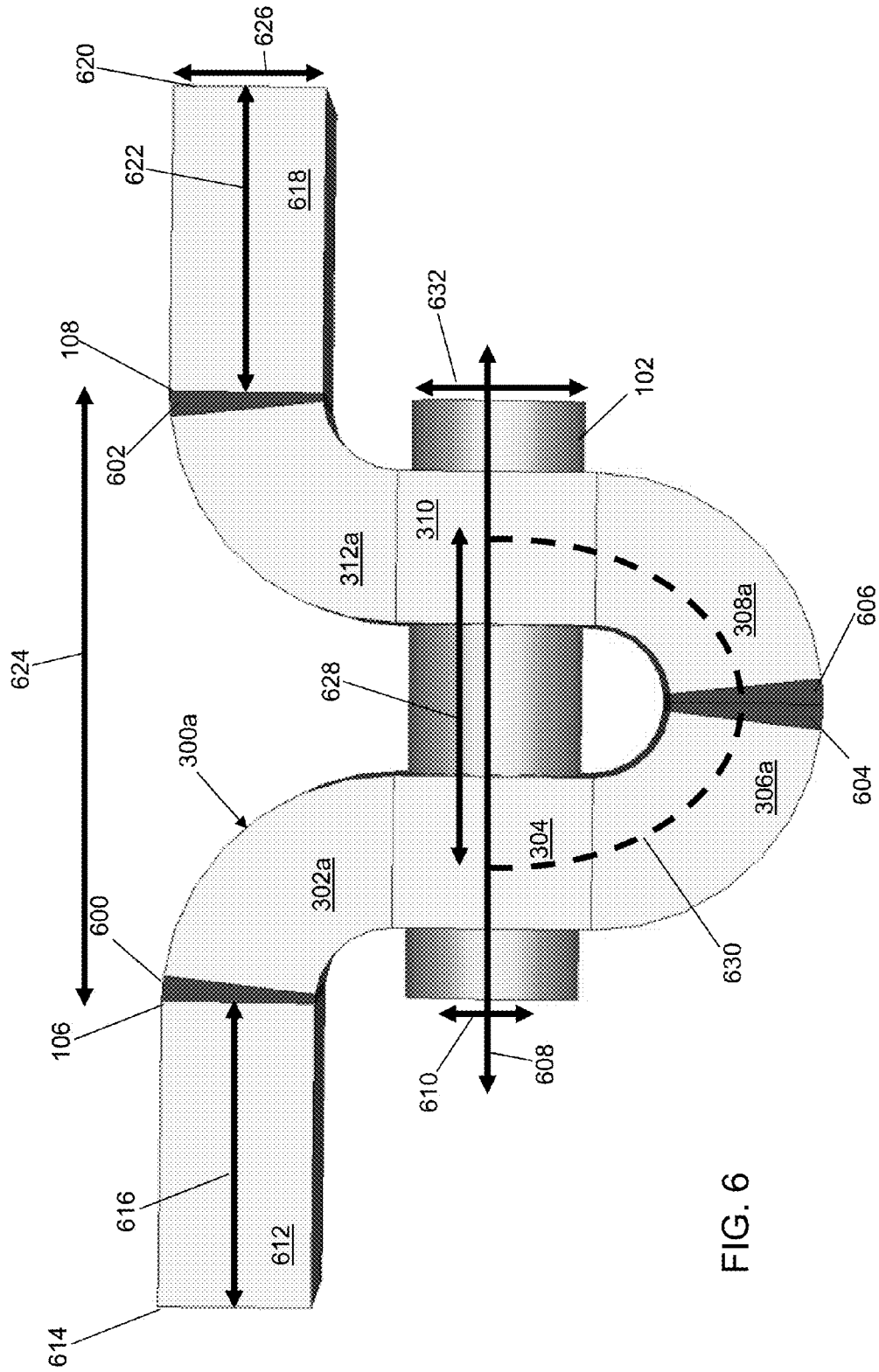

FIG. 6

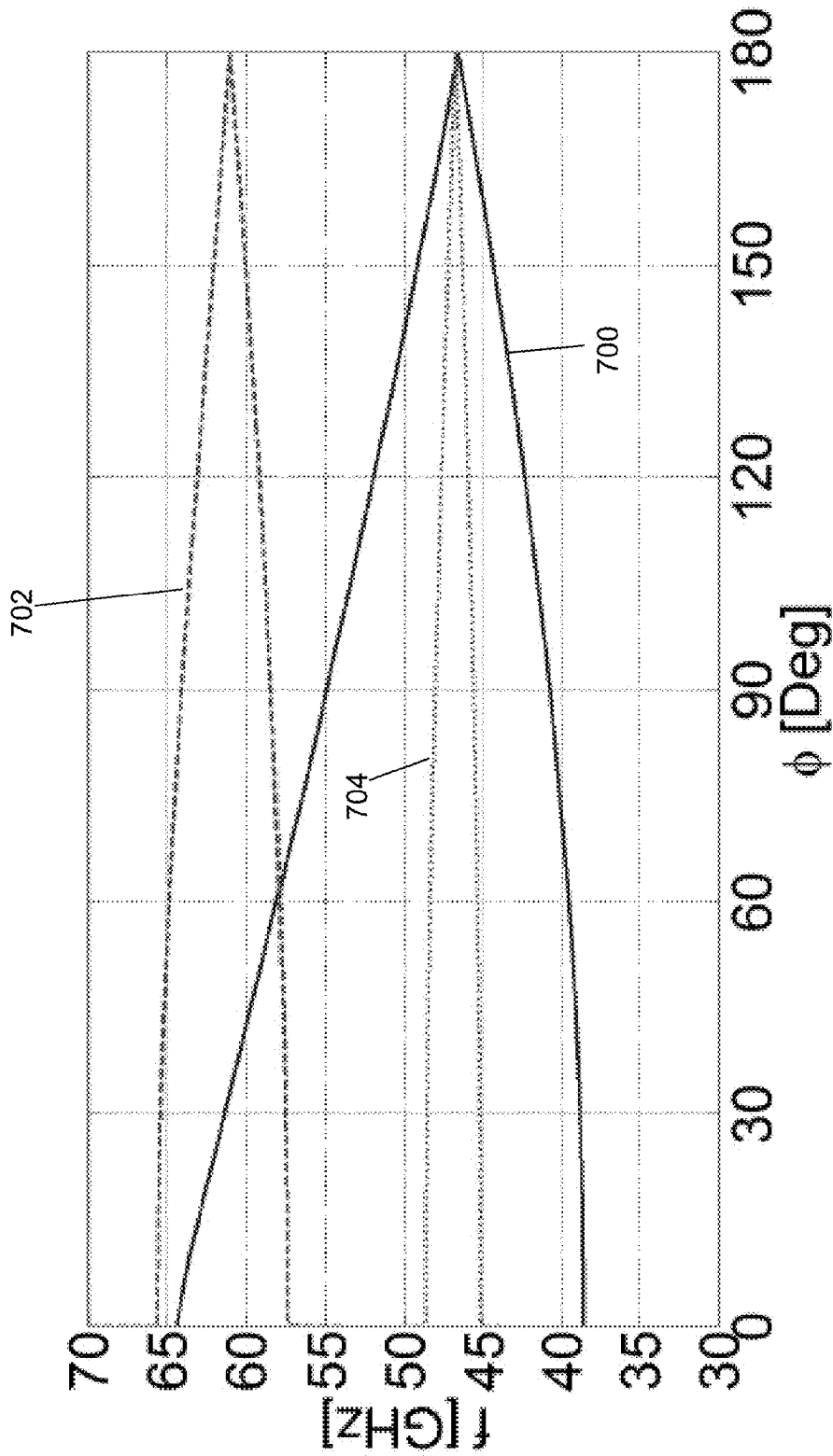

FIG. 7

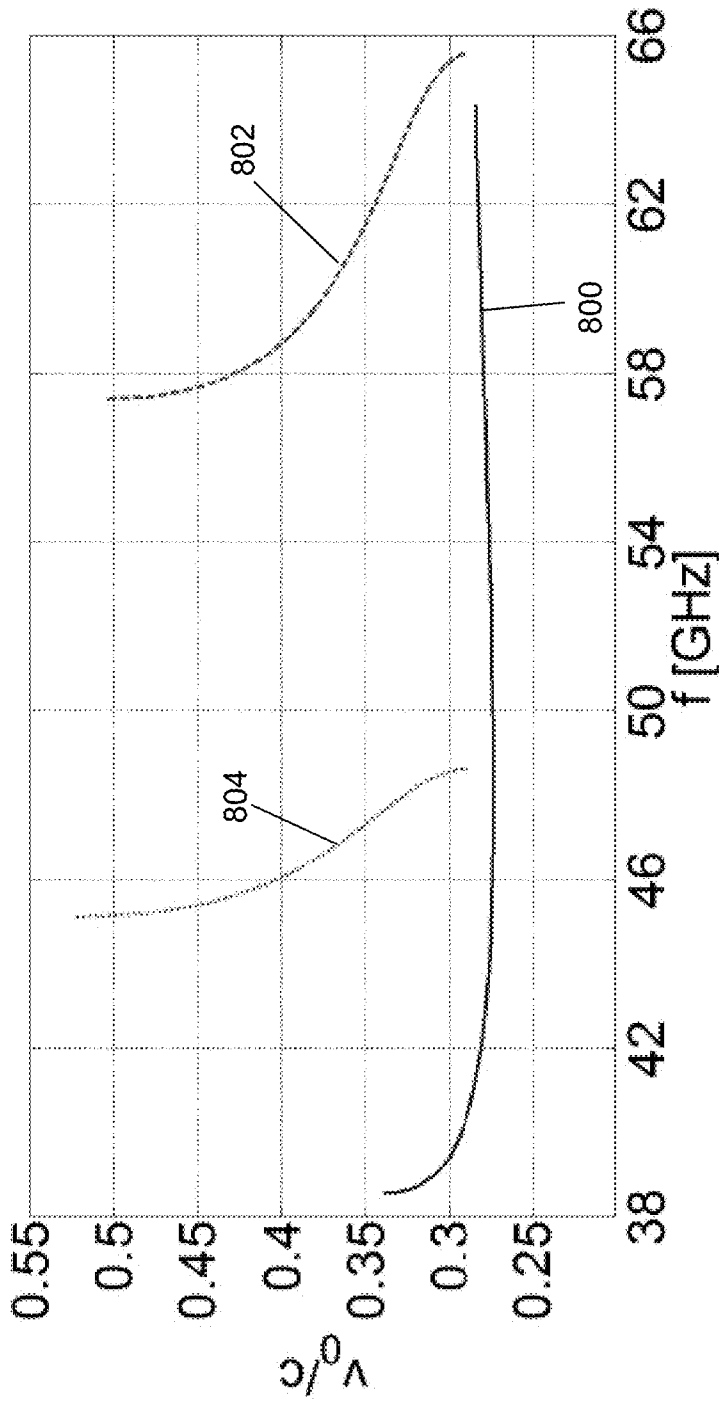

FIG. 8

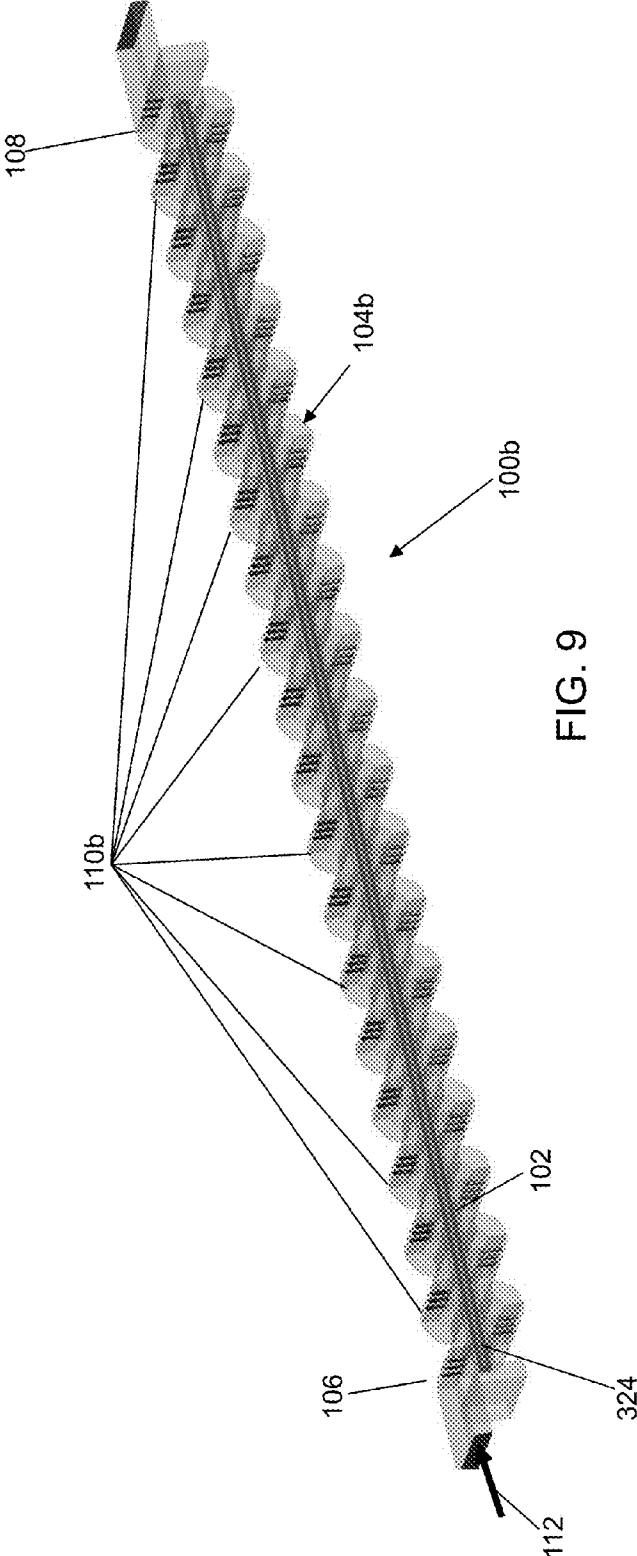
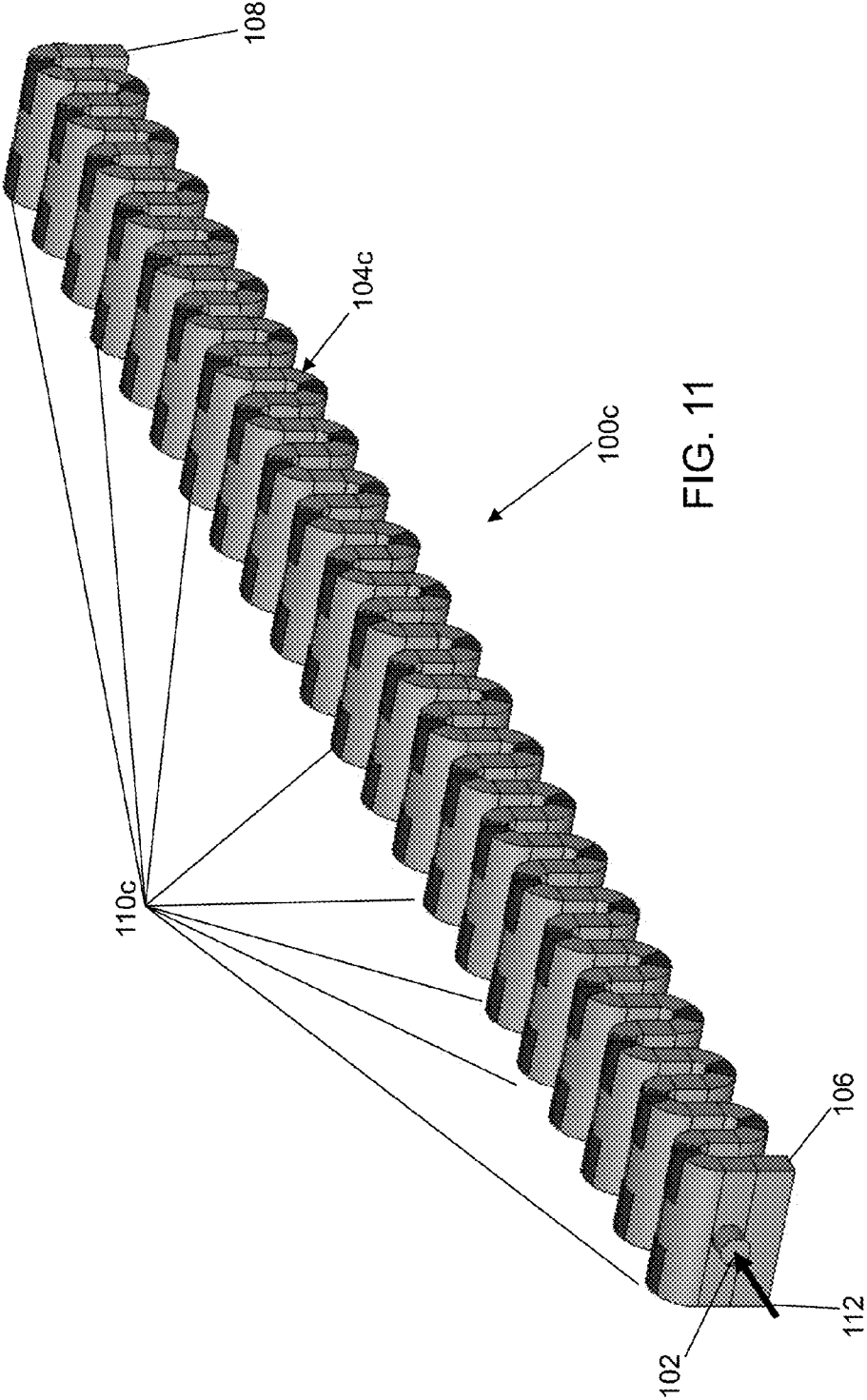

FIG. 9



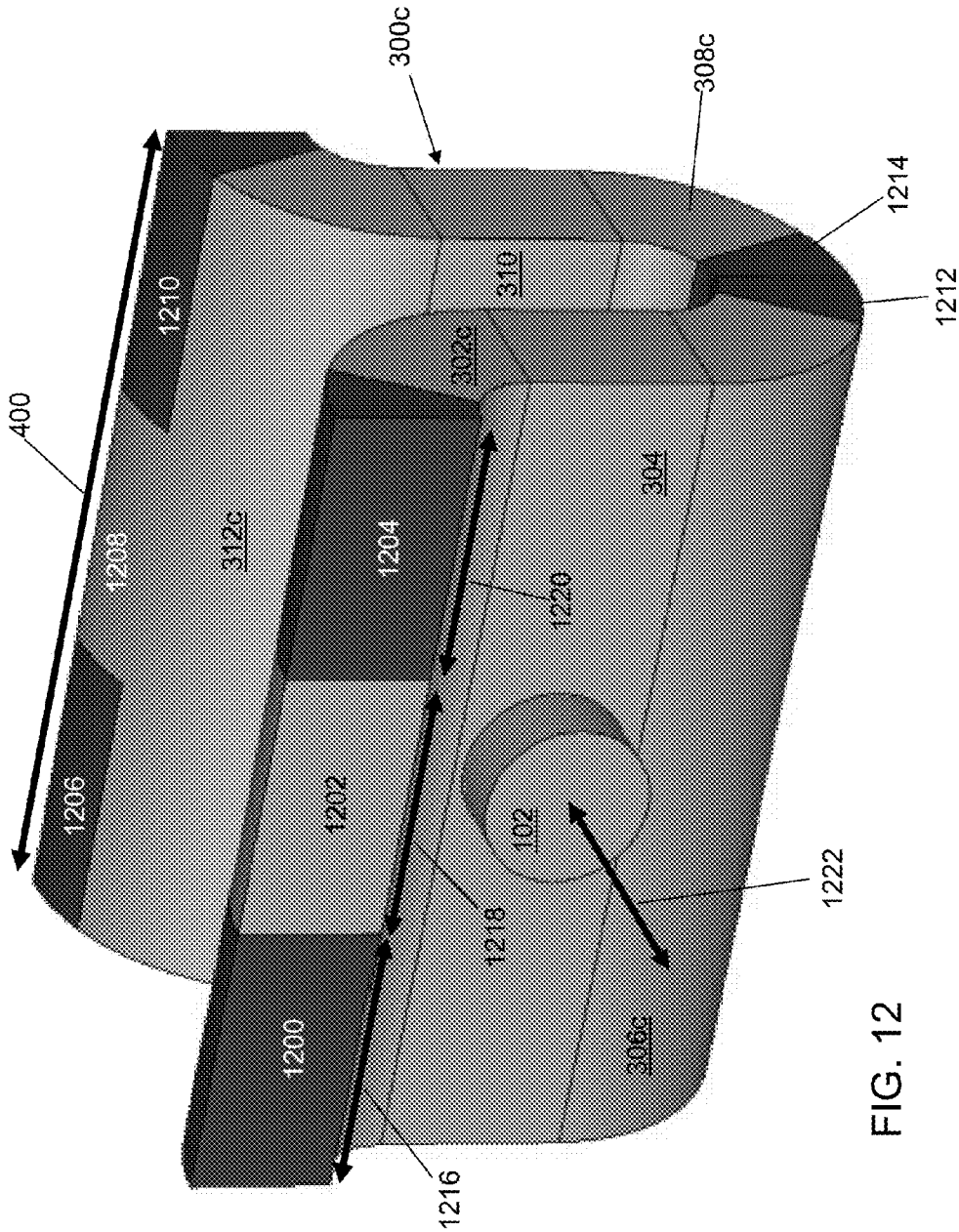

FIG. 12

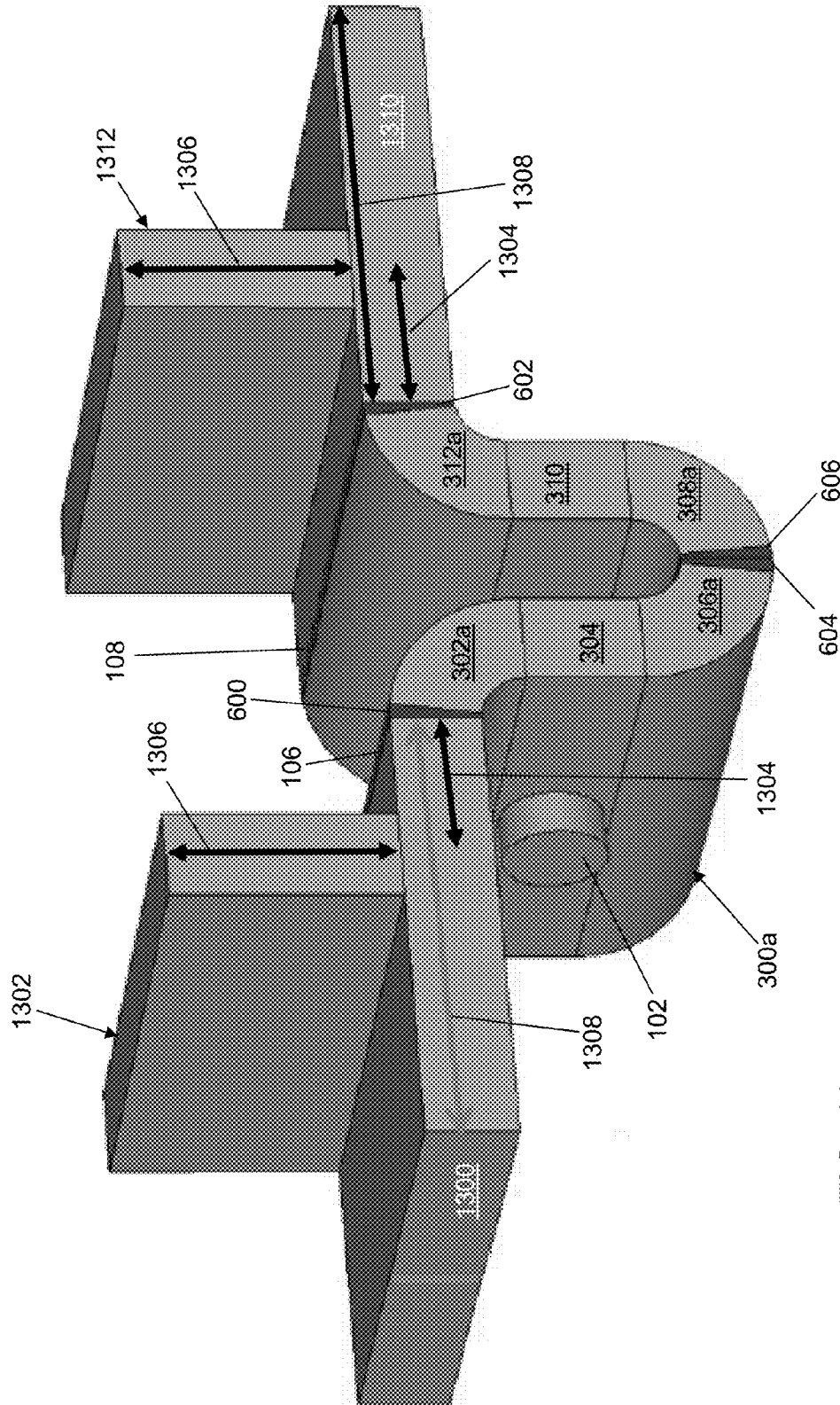

FIG. 13

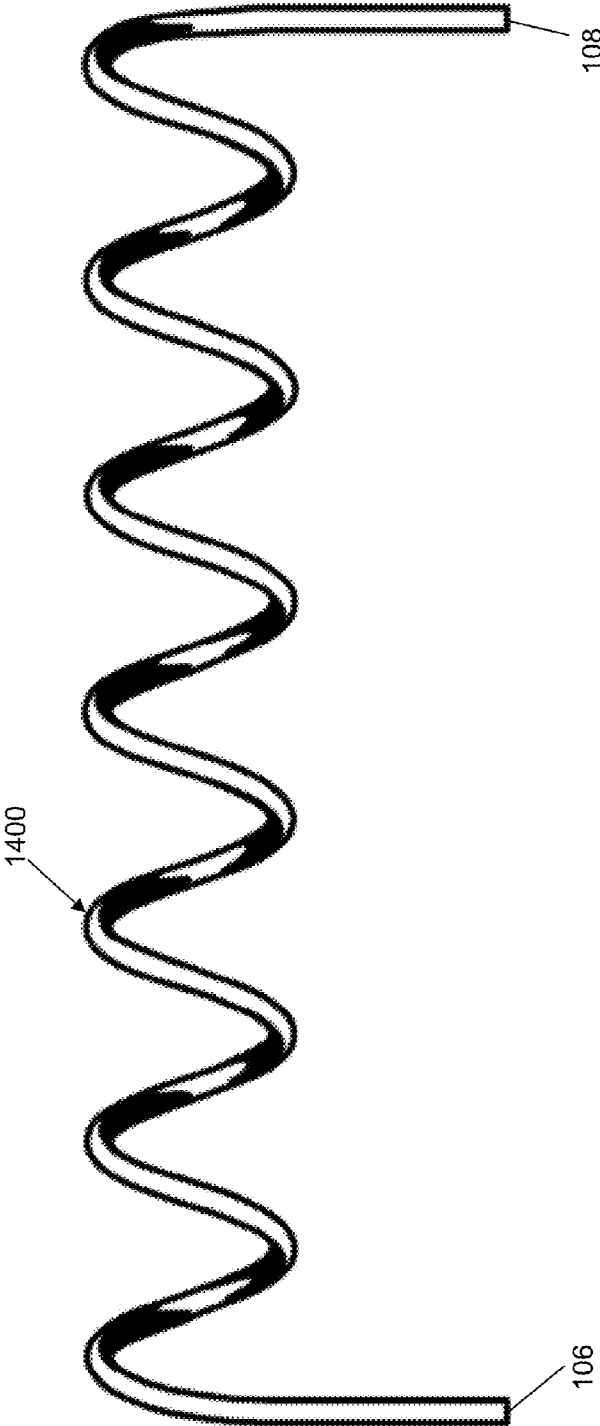

FIG. 14

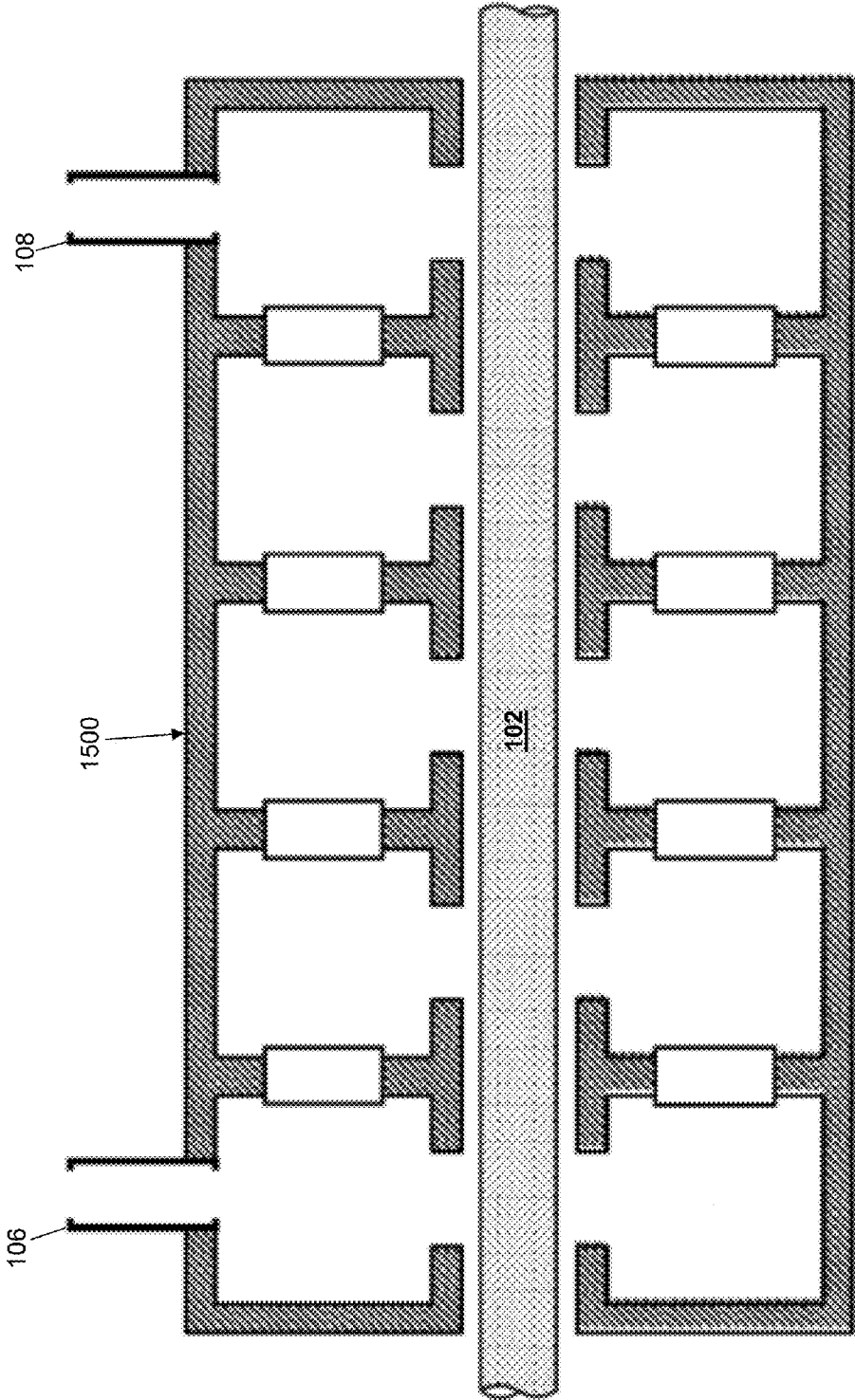

FIG. 15

**TRAVELING WAVE TUBE LOADED BY A
MATERIAL HAVING NEGATIVE
PERMITTIVITY AND POSITIVE
PERMEABILITY**

REFERENCE TO GOVERNMENT RIGHTS

This invention was made with government support under FA9550-11-1-0050 awarded by the USAF/AFOSR. The government has certain rights in the invention.

BACKGROUND

Traveling wave tubes (TWT) are used in various wireless devices including radar systems, satellite communications systems, wireless transponders of microwave backhaul links, etc. A TWT is a vacuum electronic device that acts as a microwave amplifier capable of providing a high gain and high output power. To accomplish this, TWTs use slow-wave structures that support the propagation of an electromagnetic (EM) wave and also accommodate the propagation of an energetic electron beam from within the device. The interaction between the electron beam and the EM wave results in amplification of the EM wave and a consequent boost in the amplitude of the EM wave thereby increasing the output power of the device. The gain of the device is a function of the interaction impedance and the total current of the electron beam, which is limited by the maximum dimensions of the slow-wave structure. As frequency increases, the dimensions of conventional slow-wave structures used in conventional TWTs decrease.

SUMMARY

In an illustrative embodiment, a slow wave structure of a traveling wave tube is provided. The slow wave structure includes, but is not limited to, an input port, an output port, a first material, and a second material. The second material is mounted in the first material at periodic intervals in a direction of propagation of a radio frequency signal between the input port and the output port. The second material has a real part of permittivity that is negative and a real part of permeability that is positive at an operational frequency of the radio frequency signal.

In an illustrative embodiment, a traveling wave tube is provided. The traveling wave tube includes, but is not limited to, a slow wave structure and an electron beam vacuum tube. The slow wave structure includes, but is not limited to, an input port, an output port, a first material, and a second material. The slow wave structure is configured to receive a radio frequency signal through the input port and to output an amplified radio frequency signal through the output port. The radio frequency signal has an operational frequency. The electron beam vacuum tube is configured to receive an electron beam and to focus the electron beam for transmission therethrough. The electron beam vacuum tube is mounted to extend through a center of the slow wave structure defined in a direction of propagation of the electron beam. The second material is mounted in the first material at periodic intervals in a direction of propagation of a radio frequency signal between the input port and the output port. The second material has a real part of permittivity that is negative and a real part of permeability that is positive at an operational frequency of the radio frequency signal.

Other principal features and advantages of the invention will become apparent to those skilled in the art upon review of the following drawings, the detailed description, and the appended claims.

BRIEF DESCRIPTION OF THE DRAWINGS

Illustrative embodiments of the invention will hereafter be described with reference to the accompanying drawings, wherein like numerals denote like elements, and further wherein the first digit of a three digit reference number and the first two digits of a four digit reference number indicate the figure number in which the element is at least first introduced.

FIG. 1 is a perspective view of a folded waveguide (FW) traveling wave tube (TWT) in accordance with an illustrative embodiment.

FIG. 2 is a side view of the FWTWT of FIG. 1 in accordance with an illustrative embodiment.

FIG. 3 is a side view of a unit cell of the FWTWT of FIG. 1 in accordance with an illustrative embodiment.

FIG. 4 is a perspective view of the unit cell of the FWTWT of FIG. 3 in accordance with an illustrative embodiment.

FIG. 5 is a perspective view of the FWTWT of FIG. 1 loaded with an epsilon negative material in accordance with an illustrative embodiment.

FIG. 6 is a side view of a unit cell of the loaded FWTWT of FIG. 5 in accordance with an illustrative embodiment.

FIG. 7 is a graph showing a Brillouin dispersion relation comparison.

FIG. 8 is a graph showing a phase velocity comparison.

FIG. 9 is a perspective view of the FWTWT of FIG. 1 loaded with a material that behaves similar to the epsilon negative material of FIG. 5 in accordance with an illustrative embodiment.

FIG. 10 is a perspective view of a unit cell of the loaded FWTWT of FIG. 9 in accordance with an illustrative embodiment.

FIG. 11 is a perspective view of the FWTWT of FIG. 1 loaded with a second material that behaves similar to the epsilon negative material of FIG. 5 in accordance with an illustrative embodiment.

FIG. 12 is a perspective view of a unit cell of the loaded FWTWT of FIG. 11 in accordance with an illustrative embodiment.

FIG. 13 is a perspective view of the unit cell of the loaded FWTWT of FIG. 5 with a matching network in accordance with an illustrative embodiment.

FIG. 14 is a side view of a slow wave structure in the form of a helical coil in accordance with an illustrative embodiment.

FIG. 15 is a side view of a slow wave structure in the form of a coupled cavity in accordance with an illustrative embodiment.

DETAILED DESCRIPTION

With reference to FIG. 1, a perspective view of a first traveling wave tube (TWT) 100 is shown in accordance with an illustrative embodiment. TWT 100 may include an electron beam vacuum tube 102 and a slow wave structure (SWS) 104. A radio frequency (RF) signal is input at an input end 106 of SWS 104 and is output at an output end 108 of SWS 104. The RF signal output at output end 108 is amplified relative to the RF signal input at input end 106. SWS 104 includes a plurality of unit cells 110 along a length of SWS 104 in a direction from input end 106 to output end 108. In the illustrative embodiment of FIG. 1, SWS 104 includes 19 identical unit cells that form a serpentine, rectangular folded waveguide. In alternative embodiments, SWS 104 may include a coupled cavity, a helical coil, a parallel plate folded waveguide, etc. For illustration, FIG. 14 shows a helical coil

1400 with input end 106 and output end 108 as understood by a person of skill in the art. For illustration, FIG. 15 shows a coupled cavity 1500 with input end 106, output end 108, and electron beam vacuum tube 102 as understood by a person of skill in the art. FIGS. 14 and 15 were obtained from A. S. Gilmour, Jr., *Klystrons, Traveling Wave Tubes, Magnetrons, Crossed-Field Amplifiers, and Gyrotrons* (2011) and are FIG. 14-17 and FIG. 15-2, respectively, with the text and other extraneous details omitted.

With reference to FIG. 2, a side view of TWT 100 is shown in accordance with an illustrative embodiment. Referring to FIGS. 1 and 2, electron beam vacuum tube 102 extends a length of SWS 104 from input end 106 to output end 108 and through a center of SWS 104 defined in a direction of propagation 112 of the electron beam. A coordinate reference frame 114 defines an x-direction (x in the figures), a y-direction (y in the figures), and a z-direction (z in the figures) that are mutually orthogonal and form a right-handed system. Direction of propagation 112 of the electron beam is parallel to the z-direction of coordinate reference frame 114. The x-direction and y-direction define a cross section of electron beam vacuum tube 102 perpendicular to direction of propagation 112 of the electron beam. Center of SWS 104 is defined in the x-y plane of coordinate reference frame 114.

In an illustrative embodiment, a cross section of SWS 104 perpendicular to a direction of propagation of the RF signal is rectangular though other cross sections including square, circular, and elliptical may be used in alternative embodiments. For example, a square cross section may be used in a coupled cavity SWS 104. As another example, a circular cross section may be used in a helical coil SWS 104.

Referring to FIG. 3, a unit cell 300 of SWS 104 is shown in accordance with an illustrative embodiment. Unit cell 300 includes a first waveguide section 302, a second waveguide section 304, a third waveguide section 306, a fourth waveguide section 308, a fifth waveguide section 310, and a sixth waveguide section 312 that form a continuous serpentine "U" shape. Each waveguide section is open where it mounts to the adjacent wave guide section. As understood by a person of skill in the art, the RF signal propagates in the interior of SWS 104, which may be filled with air. The walls that form first waveguide section 302, second waveguide section 304, third waveguide section 306, fourth waveguide section 308, fifth waveguide section 310, and sixth waveguide section 312 may be formed of a material that is conductive at the operational frequency, f_o , of TWT 100.

Electron beam vacuum tube 102 extends through a center of second waveguide section 304 and fifth waveguide section 310. Second waveguide section 304 and fifth waveguide section 310 are formed of rectangular cross sections defined by the walls of second waveguide section 304 and fifth waveguide section 310. Second waveguide section 304 is mounted between first waveguide section 302 and third waveguide section 306. Fifth waveguide section 310 is mounted between fourth waveguide section 308 and sixth waveguide section 312. The walls of first waveguide section 302, third waveguide section 306, fourth waveguide section 308, and sixth waveguide section 312 are curved to form an E-plane semi-circular bend in the same manner, but rotated in different directions to form the serpentine external shape.

A length 314 of unit cell 300 extends between edges of first waveguide section 302 and sixth waveguide section 312. The rectangular cross section of each waveguide section has a cross section height 316 and a cross section width 400 (shown with reference to FIG. 4). Unit cell 300 defines an electron beam path length 318 and an electromagnetic (EM) wave path

length 320. Electron beam path length 318 defines a distance between subsequent beam crossings. Electron beam vacuum tube 102 has a diameter 322.

An electron gun (not shown) generates an electron beam 324 in electron beam vacuum tube 102. Electron beam 324 is focused to a beam diameter 326 using magnets around an interior surface of electron beam vacuum tube 102 as understood by a person of skill in the art. For illustration, electrons from a heated cathode are accelerated towards an anode, which is held at a high positive potential with respect to the cathode. A portion of the electrons pass through a hole in the anode to produce electron beam 324. Electron beam 324 travels down electron beam vacuum tube 102 in the z-direction to a collector that is maintained at a high voltage relative to the cathode.

SWS 104 supports propagation of a dominant TE_{10} mode. In an illustrative embodiment, electron beam 324 passes through the tunnel of electron beam vacuum tube 102 having a radius r_c equal to half of diameter 322. In alternative embodiments, radius r_c may be larger or smaller. The axis of electron beam vacuum tube 102 is along the z-direction.

The input RF signal propagates into SWS 104 and interacts with electron beam 324 at beam crossings in second waveguide section 304 and fifth waveguide section 310 in which the TE_{10} electric field and the DC current of electron beam 324 are collinear. When electron beam 324 passes through a first beam crossing in second waveguide section 304, the electrons face the force applied by a collinear electric field of SWS 104, which is alternating at the RF operational frequency, f_o .

Due to the alternating force, some electrons are accelerated and other are decelerated. The superposition of the accelerated and decelerated electrons is translated to an RF current with the same frequency as the input RF signal. An RF current amplitude is modulated by the electric field of SWS 104 and provides an additional source of electric field that propagates through electron beam vacuum tube 102. When the electrons arrive at the next beam crossing in fifth waveguide section 310, the electrons face a stronger force applied by a summation of the electric field of SWS 104 and the electric field formed by the RF current at the previous beam crossing. In this manner, both the RF current and the electric field grow as the electrons pass the subsequent beam crossings in the subsequent unit cells of SWS 104. As a result, the RF signal output at output end 108 of SWS 104 is amplified.

The electron gun at input end 106 of SWS 104 emits the electrons with a constant velocity u_o into the tunnel of electron beam vacuum tube 102. In an illustrative embodiment, a relatively large magneto-static field B_o in the direction of the beam velocity is applied to focus electron beam 324 of radius r_b equal to half of beam diameter 326 to define an axially confined flow of electrons. In alternative embodiments, radius r_b may be larger or smaller. SWS 104 is a periodic structure that exhibits a dispersion diagram in which the lower bands of propagation support traveling waves with phase velocities much less than the speed of light.

With reference to FIG. 5, a perspective view of a second TWT 100a is shown in accordance with an illustrative embodiment. Second TWT 100a may include electron beam vacuum tube 102 and a second SWS 104a. Second SWS 104a includes a second plurality of unit cells 110a along a length of second SWS 104a in a direction from input end 106 to output end 108. In the illustrative embodiment of FIG. 5, second SWS 104a includes 19 identical unit cells that form a serpentine, rectangular folded waveguide.

An epsilon negative material (ENG) is inserted in each of the second plurality of unit cells 110a. An ENG material has

5

a real part of permittivity that is negative and a real part of permeability that is positive at the operational frequency f_o of the RF signal input at input end 106. Electron beam vacuum tube 102 extends a length of second SWS 104a from input end 106 to output end 108 and through a center of second SWS 104a defined in direction of propagation 112 of electron beam 324.

In an illustrative embodiment, a cross section of second SWS 104a perpendicular to a direction of propagation of the RF signal is rectangular. Second SWS 104a supports propagation of a dominant TE₁₀ mode.

Referring to FIG. 6, a second unit cell 300a of second SWS 104a is shown in accordance with an illustrative embodiment. Second unit cell 300a includes a seventh waveguide section 302a, second waveguide section 304, an eighth waveguide section 306a, a ninth waveguide section 308a, fifth waveguide section 310, and a tenth waveguide section 312a that form a continuous serpentine “U” shape. The dimensions of second waveguide section 304 and fifth waveguide section 310 in second unit cell 300a may be different from those used in unit cell 300. Each waveguide section is open where it mounts to the adjacent wave guide section. As understood by a person of skill in the art, the RF signal propagates in the interior of second SWS 104a, which may be filled with air. The walls that form seventh waveguide section 302a, second waveguide section 304, eighth waveguide section 306a, ninth waveguide section 308a, fifth waveguide section 310, and tenth waveguide section 312a may be formed of a material that is conductive at the operational frequency, f_o , of second TWT 100a.

Second waveguide section 304 is mounted between seventh waveguide section 302a and eighth waveguide section 306a. Fifth waveguide section 310 is mounted between ninth waveguide section 308a and tenth waveguide section 312a. the walls of seventh waveguide section 302a, eighth waveguide section 306a, ninth waveguide section 308a, and tenth waveguide section 312a are curved to form an E-plane semi-circular bend in the same manner, but rotated in different directions to form the serpentine external shape.

Seventh waveguide section 302a includes a first wedge 600 formed of ENG material. Because seventh waveguide section 302a is bent, first wedge 600 has a wedge shape. First wedge 600 is mounted across the rectangular cross section of seventh waveguide section 302a. In the illustrative embodiment, first wedge 600 is mounted across the rectangular cross section of seventh waveguide section 302a at a maximum distance from a center line 608 of second SWS 104a that is also a center line of electron beam vacuum tube 102. First wedge 600 may be mounted across the rectangular cross section of seventh waveguide section 302a at other locations.

Tenth waveguide section 312a includes a second wedge 602 formed of ENG material. Because tenth waveguide section 312a is bent, second wedge 602 forms a wedge shape. Second wedge 602 is mounted across the rectangular cross section of tenth waveguide section 312a. In the illustrative embodiment, second wedge 602 is mounted across the rectangular cross section of tenth waveguide section 312a at a maximum distance from center line 608 of second SWS 104a. Second wedge 602 may be mounted across the rectangular cross section of tenth waveguide section 312a at other locations.

Eighth waveguide section 306a includes a third wedge 604 formed of ENG material similar to first wedge 600 and second wedge 602. Ninth waveguide section 308a includes a fourth wedge 606 formed of ENG material similar to first wedge 600, second wedge 602, and third wedge 604. First wedge

6

600, second wedge 602, third wedge 604, and fourth wedge 606 have the same size and shape.

Each second unit cell 300a of the second plurality of unit cells 110a is identical and includes first wedge 600, second wedge 602, third wedge 604, and fourth wedge 606. First wedge 600, second wedge 602, third wedge 604, and fourth wedge 606 are mounted in second SWS 104a at periodic intervals in a direction of propagation of the RF signal through second SWS 104a or transverse to the serpentine path of the propagating RF signal. In the illustrative embodiment, air or vacuum is on either side of first wedge 600, second wedge 602, third wedge 604, and fourth wedge 606.

The electromagnetic effect of first wedge 600, second wedge 602, third wedge 604, and fourth wedge 606 can be characterized by assuming a straight waveguide loaded by an ENG slab of material having a thickness τ . The permittivity, ϵ_r , can be characterized by the lossless Drude model as

$$\epsilon_r = 1 - \left(\frac{f_p^{ENG}}{f} \right)^2,$$

where f_p^{ENG} is the Drude plasma frequency and f is the operational frequency also denoted as f_o herein. For the TE₁₀ mode propagating through the straight waveguide, the ENG slab is modeled by a short transmission line (TL) sandwiched between two transmission lines that represent the air-filled waveguide on either side of the ENG slab. Assuming a normalized characteristic impedance for the air-filled waveguide to be $Z_{air}=1$. The TE₁₀ normalized characteristic impedance, Z_{ENG} , for the ENG-filled waveguide is $Z_{ENG}=\beta_{air}/\beta_{ENG}$, where

$$\beta_{air} = \sqrt{\left(\frac{2\pi f}{c} \right)^2 - \left(\frac{\pi}{a} \right)^2} \quad \text{and} \quad \beta_{ENG} = \sqrt{\epsilon_r \left(\frac{2\pi f}{c} \right)^2 - \left(\frac{\pi}{a} \right)^2},$$

where c is the speed of light and a is cross section width 400 and β_{air} and β_{ENG} are the TE₁₀ phase constants for the air-filled waveguide and the ENG-filled waveguide, respectively.

The electrically short TL corresponding to the ENG-filled waveguide can be modeled by a two port T-network that includes lumped series and shunt elements, with normalized impedances Z_s and Z_p , respectively. By making the ABCD-matrices for the ENG-filled TL and T-network equal to each other, the normalized series and shunt impedances in the T-network are evaluated as $Z_p=-jZ_{ENG}/\sin(\theta_{ENG})$ and $Z_s=(\cos(\theta_{ENG})-1)Z_p$, where $\theta_{ENG}=\beta_{ENG}\tau$. If θ_{ENG} is small, $Z_s \approx 0$ and

$$\bar{Z}_p = j \frac{\beta_{air}}{\left[-\epsilon_r \left(\frac{2\pi f}{c} \right)^2 + \left(\frac{\pi}{a} \right)^2 \right] \tau}$$

Because ϵ_r is negative, the normalized shunt impedance is purely inductive. As a result, the relatively thin ENG-filled waveguide acts as a shunt inductance loading the equivalent TL of the air-filled waveguide. A shunt inductance increases the phase velocity of the propagating RF signal through the waveguide. Therefore, the bands of propagation are shifted up to higher frequencies.

As just explained, first wedge 600, second wedge 602, third wedge 604, and fourth wedge 606 formed of ENG material

act as a shunt inductance periodically loading an equivalent Bloch transmission line model of SWS **104**. A shunt inductance increases the phase velocity of the propagating RF signal through second SWS **104a**. By periodically loading second SWS **104a**, the bands of propagation are shifted up to higher frequencies, for example, from an operational frequency, f_0 , to a higher frequency $f_1 > f_0$. To operate second TWT **100a** at the operational frequency f_0 , the size of second TWT **100a** is increased by a scale factor defined by f_1/f_0 . The scale factor is selected to include the unloaded operational frequency, f_0 , within the propagation band of second SWS **104a**. A unit-cell phase shift of between 180° and 360° for the EM signal propagating through second SWS **104a** is large enough to achieve a relatively slow zeroth-order spatial harmonic propagating inside electron beam vacuum tube **102**. The scale factor is selected to avoid bringing second TWT **100a** into cut-off, which occurs when the unit-cell phase shift equals 180° or 360° . Based on this, a desired scale factor may provide a unit-cell phase shift around 270° . As an example, for TWT **100**, the operational frequency may be 48 GHz. Second TWT **100a**, made from TWT **100**, by adding first wedge **600**, second wedge **602**, third wedge **604**, and fourth wedge **606** formed of ENG material, results in a propagation band that is shifted up to higher frequencies. For the unit-cell phase shift equal to 270° , the operational frequency for the ENG loaded second TWT **100a** is 64 GHz, which is higher than the unloaded operational frequency of 48 GHz. To bring down the operational frequency of the ENG loaded second TWT **100a** to the desired operational frequency of 48 GHz, the dimensions of the ENG loaded second TWT **100a** are enlarged by a scale factor equal to

$$\frac{f_1}{f_0} = \frac{64}{48} = 1.33.$$

in an illustrative embodiment, the scale factor used was 1.35 to enlarge the ENG loaded second TWT **100a**. The corresponding unit-cell phase shift for the scale factor equal to 1.35 was 267.1° which is approximately equal to 270° .

A length **624** of second unit cell **300a** extends between edges of seventh waveguide section **302a** and tenth waveguide section **312a**. The rectangular cross section of each waveguide section has a cross section height **626** and a cross section width (not shown). Second unit cell **300a** defines an electron beam path length **628** and an EM wave path length **630**. Electron beam vacuum tube **102** has a second beam diameter **610** and a diameter **632**. Length **624**, cross section height **626**, and the cross section width of second unit cell **300a** are increased by the scale factor thereby increasing electron beam path length **628** and EM wave path length **630**. Second beam diameter **610** of second SWS **104a** is larger than beam diameter **326** of SWS **104** by the scale factor supporting a larger current at the same operational frequency of SWS **104**. Second TWT **100a** further has a higher interaction impedance compared to TWT **100**, which increases the gain.

In an illustrative embodiment, an average arc-length L_{wedge} of each wedge may be selected as EM wave path length **630** divided by 20. The apex of the angle of the combined third wedge **604** and fourth wedge **606** at the intersection of eighth waveguide section **306a** and ninth waveguide section **308a** is $\theta_{wedge} = 2L_{wedge}/p$, where p is electron beam path length **628**. If θ_{wedge} is larger than a threshold, such as 90° , the wedge may reduce a longitudinal component of the electric field in electron beam vacuum tube **102**, which decreases the interaction impedance and degrades the gain performance of second

TWT **100a**. To avoid this, θ_{wedge} is generally small. For illustration, $\theta_{wedge} = 12.7^\circ$ was used in an illustrative embodiment.

To perform a cold test of second TWT **100a**, an A-element in the ABCD-matrix associated with second unit cell **300a** is determined. To calculate the ABCD-matrix of second unit cell **300a**, a first rectangular waveguide **612** is mounted between an input port **614** and first wedge **600** and has a first longitudinal length **616**, and a second rectangular waveguide **618** is mounted between an output port **620** and second wedge **602** and has a second longitudinal length **622**. First rectangular waveguide **612** and second rectangular waveguide **618** have the same transverse cross section as second SWS **104a** at input end **106** and at output end **108** of second unit cell **300a**. First rectangular waveguide **612**, second unit cell **300a**, and second rectangular waveguide **618** form three-stages.

The reason for adding the input waveguide **612** and output waveguide **618** is to make the reference impedance the same as the TE_{10} characteristic impedance of the air-filled straight waveguide. The s-parameters of the three-stage cascaded network depicted in FIG. **6** are calculated. For example, a frequency domain solver with a tetrahedral mesh type in CST Microwave Studio® marketed by CST Computer Simulation Technology AG may be used to analyze the s-parameters of the cascaded network over a frequency range. Using the calculated s-parameters, the corresponding ABCD-matrix, $[T]_{cas}$ is calculated as described in D. M. Pozar, *Microwave Engineering*, Hoboken, N.J., John Wiley and Sons, 2012. The ABCD-matrix of second unit cell **300a**, $[T]_{unit}$, is calculated as $[T]_{unit} = [T]_{\omega}^{-1} [T]_{cas} [T]_{\omega}^{-1}$, where $[T]_{\omega}$ is calculated analytically as described in D. M. Pozar, *Microwave Engineering*, Hoboken, N.J., John Wiley and Sons, 2012 using the TE_{10} characteristic impedance and the phase constant of the rectangular waveguide. The Brillouin phase shift between input end **106** and output end **108** of second unit cell **300a** is calculated as $\Theta = \cos^{-1} A_{unit}$ where A_{unit} is the A-element of the unit-cell ABCD-matrix calculated as described in R. E. Collin, *Foundations for Microwave Engineering*, 2nd ed., Hoboken, N.J., John Wiley and Sons, 2001.

For illustration, a dispersion diagram for an RF wave is shown in FIG. **7**. FIG. **7** shows a first dispersion curve **700**, a second dispersion curve **702**, and a third dispersion curve **704** as a function of phase, ϕ , in degrees (Deg) and frequency f in gigahertz (GHz). First dispersion curve **700** was calculated using TWT **100**. Second dispersion curve **702** was calculated using second TWT **100a** with the same dimensions as TWT **100**. Third dispersion curve **704** was calculated using second TWT **100a** increased in size relative to TWT **100** by the scale factor. The dispersion diagram shows that the propagation band in second TWT **100a** is shifted up to the higher frequencies compared to that for TWT **100**. To bring down the band of propagation, 'reverse-miniaturization' is performed which means scaling up the dimensions of second TWT **100a** by the scale factor.

A unit cell phase shift, ψ , should be large enough at f_0 to achieve a relatively slow phase velocity for a zeroth order spatial harmonic inside the enlarged tunnel of electron beam vacuum tube **102**. A preferable operational region in the propagation band of enlarged second TWT **100a** is a second eigen mode for which $180^\circ < \psi < 360^\circ$. However, f_0 should be far away from the upper cut-off frequency for which $\psi = 360^\circ$. Therefore, $\psi = 270^\circ$ is a relatively good choice. For third dispersion curve **704**, $\psi = 267.1^\circ$ was used.

A slow wave velocity diagram for an RF wave is shown in FIG. **8**. FIG. **8** shows a first velocity curve **800**, a second velocity curve **802**, and a third velocity curve **804** as a function of frequency f in gigahertz (GHz) and V_0/c where V_0 is the electron velocity and c is the speed of light. First velocity

curve **800** was calculated using TWT **100**. Second velocity curve **802** was calculated using second TWT **100a** with the same dimensions as TWT **100**. Third velocity curve **804** was calculated using second TWT **100a** increased in size relative to TWT **100** by the scale factor. At f_0 , the slow wave phase velocity for the enlarged second TWT **100a** was slightly faster than for TWT **100**. The bandwidth is narrower for the enlarged second TWT **100a**.

With reference to FIG. 9, a perspective view of a third TWT **100b** is shown in accordance with an illustrative embodiment. Third TWT **100b** may include electron beam vacuum tube **102** and a third SWS **104b**. Third SWS **104b** includes a third plurality of unit cells **110b** along a length of third SWS **104b** in a direction from input end **106** to output end **108**. In the illustrative embodiment of FIG. 9, third SWS **104b** includes 19 identical unit cells that form a serpentine, rectangular folded waveguide. A plurality of wires are inserted in each of the third plurality of unit cells **110b**. Electron beam vacuum tube **102** extends a length of third SWS **104b** from input end **106** to output end **108** and through a center of third SWS **104b** defined in direction of propagation **112** of electron beam **324**.

In an illustrative embodiment, a cross section of third SWS **104b** perpendicular to the direction of propagation of the RF signal is rectangular. Third SWS **104b** supports propagation of a dominant TE_{10} mode.

Referring to FIG. 10, a third unit cell **300b** of third TWT **100b** is shown in accordance with an illustrative embodiment. Third unit cell **300b** includes an eleventh waveguide section **302b**, second waveguide section **304**, a twelfth waveguide section **306b**, a thirteenth waveguide section **308b**, fifth waveguide section **310**, and a fourteenth waveguide section **312b** that form a continuous serpentine “U” shape. The dimensions of second waveguide section **304** and fifth waveguide section **310** in third unit cell **300b** may be different from those used in unit cell **300**. Each waveguide section is open where it mounts to the adjacent waveguide section. Second waveguide section **304** is mounted between eleventh waveguide section **302b** and twelfth waveguide section **306b**. Fifth waveguide section **310** is mounted between thirteenth waveguide section **308b** and fourteenth waveguide section **312b**. The walls of eleventh waveguide section **302b**, twelfth waveguide section **306b**, thirteenth waveguide section **308b**, and fourteenth waveguide section **312b** are curved to form an E-plane semi-circular bend in the same manner, but rotated in different directions to form the serpentine external shape.

Eleventh waveguide section **302b** includes a first plurality of wires **1000**. The first plurality of wires **1000** may be formed of a metal material and mounted to extend lengthwise across a portion of the cross section of eleventh waveguide section **302b**. In the illustrative embodiment, the first plurality of wires **1000** includes three wires that extend lengthwise between the longer sides of the rectangular cross section of eleventh waveguide section **302b**. In the illustrative embodiment, the first plurality of wires **1000** are mounted across the rectangular cross section of eleventh waveguide section **302b** at a maximum distance from a center line **1008** of third SWS **104b** that is also a center line of electron beam vacuum tube **102**, wherein center line **1008** defines a line that extends through a center of second waveguide section **304** of third unit cell **300b** in the x-direction and the y-direction of coordinate reference frame **114**. The first plurality of wires **1000** may be mounted across the rectangular cross section of eleventh waveguide section **302b** at other locations in different arrangements along third SWS **104b**. For example, multiple arrays of the first plurality of wires may be included at different locations in eleventh waveguide section **302b** in alternative embodiments.

Fourteenth waveguide section **312b** includes a second plurality of wires **1002** similar to first plurality of wires **1000**. Twelfth waveguide section **306b** includes a third plurality of wires **1004** similar to the first plurality of wires **1000** and the second plurality of wires **1002**. Thirteenth waveguide section **308b** includes a fourth plurality of wires **1006** similar to the first plurality of wires **1000**, the second plurality of wires **1002**, and the third plurality of wires **1004**. The first plurality of wires **1000**, the second plurality of wires **1002**, the third plurality of wires **1004**, and the fourth plurality of wires **1006** have the same size and shape.

Each third unit cell **300b** of the third plurality of unit cells **110b** is identical and includes the first plurality of wires **1000**, the second plurality of wires **1002**, the third plurality of wires **1004**, and the fourth plurality of wires **1006**. The first plurality of wires **1000**, the second plurality of wires **1002**, the third plurality of wires **1004**, and the fourth plurality of wires **1006** are mounted in third SWS **104b** at periodic intervals in a direction of propagation of the RF signal through third SWS **104b** or transverse to the serpentine path of the propagating RF signal. In the illustrative embodiment, vacuum surrounds each wire of the first plurality of wires **1000**, the second plurality of wires **1002**, the third plurality of wires **1004**, and the fourth plurality of wires **1006** except for the walls of third SWS **104b**. In an illustrative embodiment, a cross section of each wire is square though other shapes may be used. Each wire in each plurality of wires is separated from the adjacent wire by a spacing g and has a diameter d .

To determine a value of g and d for the plurality of wires **1000**, **1002**, **1004**, **1006** that provide a similar performance to the ENG filled wedges **600**, **602**, **604**, **606**, a cascaded network equivalent to that shown in FIG. 6 is determined. The values of g and d are selected so that a scattering matrix of third SWS **104b** is as close as possible to a scattering matrix of second SWS **104a** at the operational frequency, f_0 . The values of g and d may be selected by analyzing the wire grid cascaded network and iterating through various values of g and d to optimize the scattering matrix of third SWS **104b** so that it is as close as possible to second SWS **104a** at the operational frequency, f_0 . Because the cascaded networks are lossless, optimizing on a magnitude and a phase of s_{11} is sufficient.

With reference to FIG. 11, a perspective view of a fourth TWT **100c** is shown in accordance with an illustrative embodiment. Fourth TWT **100c** may include electron beam vacuum tube **102** and a fourth SWS **104c**. Fourth SWS **104c** includes a fourth plurality of unit cells **110c** along a length of fourth SWS **104c** in a direction from input end **106** to output end **108**. In the illustrative embodiment of FIG. 11, fourth SWS **104c** includes 19 identical unit cells that form a serpentine, rectangular folded waveguide. Electron beam vacuum tube **102** extends a length of fourth SWS **104c** from input end **106** to output end **108** and through a center of fourth SWS **104c** defined in direction of propagation **112** of electron beam **324**.

In an illustrative embodiment, a cross section of fourth SWS **104c** perpendicular to the direction of propagation of the RF signal is rectangular. Fourth SWS **104c** supports propagation of a dominant TE_{10} mode.

Referring to FIG. 12, a fourth unit cell **300c** of fourth TWT **100c** is shown in accordance with an illustrative embodiment. Fourth unit cell **300c** includes a fifteenth waveguide section **302c**, second waveguide section **304**, a sixteenth waveguide section **306c**, a seventeenth waveguide section **308c**, fifth waveguide section **310**, and an eighteenth waveguide section **312c** that form a continuous serpentine “U” shape. The dimensions of second waveguide section **304** and fifth

waveguide section **310** in fourth unit cell **300c** may be different from those used in unit cell **300**. Each waveguide section is open where it joins the adjacent waveguide section. Second waveguide section **304** is mounted between fifteenth waveguide section **302c** and sixteenth waveguide section **306c**. Fifth waveguide section **310** is mounted between seventeenth waveguide section **308c** and eighteenth waveguide section **312c**. The walls of fifteenth waveguide section **302c**, sixteenth waveguide section **306c**, seventeenth waveguide section **308c**, and eighteenth waveguide section **312c** are curved to form an E-plane semi-circular bend in the same manner, but rotated in different directions to form the serpentine external shape.

Fifteenth waveguide section **302c** includes a first plate **1200**, a second plate **1202**, and a third plate **1204**. First plate **1200** and third plate **1204** may be formed of a metal material and mounted to extend lengthwise across a portion of the cross section of fifteenth waveguide section **302c**. Second plate **1202** may be formed of another material including vacuum such that second plate **1202** is formed by the adjacent walls of first plate **1200** and third plate **1204** and of fifteenth waveguide section **302c**. A greater or a fewer number of plates may be mounted to extend lengthwise across a portion of the cross section of fifteenth waveguide section **302c**. In the illustrative embodiment, first plate **1200** and third plate **1204** extend lengthwise between the longer sides of the rectangular cross section of fifteenth waveguide section **302c** and only partially lengthwise between shorter sides of the rectangular cross section of fifteenth waveguide section **302c** to leave an air gap that forms second plate **1202**. In the illustrative embodiment, first plate **1200**, second plate **1202**, and third plate **1204** are mounted across the rectangular cross section of fifteenth waveguide section **302c** at a maximum distance from a center line **1222** of fourth SWS **104c** that is also a center line of electron beam vacuum tube **102**, wherein center line **1222** defines a line that extends through a center of second waveguide section **304** of fourth unit cell **300c** in the x-direction and the y-direction of coordinate reference frame **114**. First plate **1200**, second plate **1202**, and third plate **1204** may be mounted across the rectangular cross section of fifteenth waveguide section **302c** at other locations.

Eighteenth waveguide section **312c** includes a fourth plate **1206**, a fifth plate **1208**, and a sixth plate **1210** similar to first plate **1200**, second plate **1202**, and third plate **1204**, respectively. Sixteenth waveguide section **306c** includes a seventh plate (not shown), an eighth plate (not shown), and a ninth plate **1212** similar to first plate **1200**, second plate **1202**, and third plate **1204**, respectively. Seventeenth waveguide section **308c** includes a tenth plate (not shown), an eleventh plate (not shown), and a twelfth plate **1214** similar to first plate **1200**, second plate **1202**, and third plate **1204**, respectively.

Each fourth unit cell **300c** of the fourth plurality of unit cells **110c** is identical. The plates are mounted in fourth SWS **104c** at periodic intervals in a direction of propagation of the RF signal through fourth SWS **104c** or transverse to the serpentine path of the propagating RF signal. First plate **1200** has a first width **1216**, second plate **1202** has a second width **1218**, and third plate **1204** has a third width **1220**. A sum of first width **1216**, second width **1218**, and third width **1220** is equal to the cross section width of each waveguide section **302c**, **304**, **306c**, **308c**, **310**, **312c**.

In an illustrative embodiment, the middle plates, such as second plate **1202** and fifth plate **1208**, form a cut-off waveguide. First width **1216** and third width **1220** each have a width equal to approximately 35% of the cross section width

of the associated waveguide section. Second width **1218** is approximately 30% of the cross section width of the associated waveguide section.

With reference to FIG. **13**, a perspective view of second unit cell **300a** is shown with a matching network designed to match the input/output waveguide to avoid reflection of the incident power in accordance with an illustrative embodiment. Third unit cell **300b** and fourth unit cell **300c** may be similarly matched. To design the matching network, the Bloch impedance of second TWT **100a** is matched to the characteristic impedance (TE_{10} mode) of the input/output waveguide. The matching network illustrated in FIG. **13** includes an input waveguide **1300** and an input stub tuner **1302**. Input waveguide **1300** is mounted to first wedge **600** of seventh waveguide section **302a** to provide the RF input signal. Input stub tuner **1302** mounts to and extends perpendicular from input waveguide **1300** at a distance **1304** from first wedge **600** of seventh waveguide section **302a**. Input stub tuner **1302** may be mounted to extend either up or down from input waveguide **1300**. Input stub tuner **1302** has a height **1306** and input waveguide **1300** has a length **1308**.

Because of the symmetry, the output matching network is a mirrored version of the input one. As a result, the matching network illustrated in FIG. **13** includes an output waveguide **1310** and an output stub tuner **1312**. Output waveguide **1310** is mounted to second wedge **602** of tenth waveguide section **312a** to provide the RF output signal. Output stub tuner **1312** mounts to and extends perpendicular from output waveguide **1310** at distance **1304** from second wedge **602** of tenth waveguide section **312a**. Output stub tuner **1312** may be mounted to extend either up or down from output waveguide **1310**. Output stub tuner **1312** has height **1306** and output waveguide **1310** has length **1308**.

For TWT **100**, a matching network may not be needed because the TE_{10} characteristic impedances of the folded and straight waveguides is very close. However, for second TWT **100a**, there may be a large difference between the Bloch impedance and the TE_{10} characteristic impedance of the waveguide.

To calculate the Bloch impedance Z_B , the B- and C-elements of the ABCD-matrix associated with the enlarged second TWT **100a** is determined as

$$Z_B = \sqrt{\frac{B_{unit}}{C_{unit}}}$$

Distance **1304** and height **1306** can be computed using either a Smith chart or the analytical formulas described in D. M. Pozar, *Microwave Engineering*, Hoboken, N.J., John Wiley and Sons, 2012.

As used in this disclosure, the term “mount” includes join, unite, connect, couple, associate, insert, hang, hold, affix, attach, fasten, bind, paste, secure, bolt, screw, rivet, pin, nail, clasp, clamp, cement, fuse, solder, weld, glue, form over, slide together, layer, and other like terms. The phrases “mounted on” and “mounted to” include any interior or exterior portion of the element referenced. These phrases also encompass direct connection (in which the referenced elements are in direct contact) and indirect connection (in which the referenced elements are not in direct contact, but are mounted together via intermediate elements). Elements referenced as mounted to each other herein may further be integrally formed together. As a result, elements described herein as being mounted to each other need not be discrete

13

structural elements. The elements may be mounted permanently, removably, or releasably.

The word "illustrative" is used herein to mean serving as an example, instance, or illustration. Any aspect or design described herein as "illustrative" is not necessarily to be construed as preferred or advantageous over other aspects or designs. Further, for the purposes of this disclosure and unless otherwise specified, "a" or "an" means "one or more". Still further, the use of "and" or "or" is intended to include "and/or" unless specifically indicated otherwise.

The foregoing description of illustrative embodiments of the invention has been presented for purposes of illustration and of description. It is not intended to be exhaustive or to limit the invention to the precise form disclosed, and modifications and variations are possible in light of the above teachings or may be acquired from practice of the invention. The embodiments were chosen and described in order to explain the principles of the invention and as practical applications of the invention to enable one skilled in the art to utilize the invention in various embodiments and with various modifications as suited to the particular use contemplated. It is intended that the scope of the invention be defined by the claims appended hereto and their equivalents.

What is claimed is:

1. A slow wave structure of a traveling wave tube comprising:

- a tube;
- an input port at a second end of the tube;
- an output port at a second end of the tube;
- a first material mounted within the tube between the input port and the output port; and
- a second material, wherein the second material is mounted in the first material at periodic intervals in a direction of propagation of a radio frequency signal between the input port and the output port, and the second material has a real part of permittivity that is negative and a real part of permeability that is positive at an operational frequency of the radio frequency signal.

2. The slow wave structure of claim 1, wherein the tube is a helical coil formed by the first material and the second material, and the second material is mounted across at least a portion of the cross section of the helical coil.

3. The slow wave structure of claim 1, wherein the first material is vacuum.

4. The slow wave structure of claim 3, wherein the tube is a coupled cavity waveguide having a cross section perpendicular to the direction of propagation of the radio frequency signal.

5. The slow wave structure of claim 4, wherein the second material is mounted across at least a portion of the cross section of the coupled cavity waveguide.

6. The slow wave structure of claim 3, wherein the tube is a folded waveguide having a cross section perpendicular to the direction of propagation of the radio frequency signal.

7. The slow wave structure of claim 6, wherein the second material is mounted across at least a portion of the cross section of the folded waveguide.

8. A traveling wave tube comprising:
- a slow wave structure comprising
 - an input port at a first end of the slow wave structure;
 - an output port at a second end of the slow wave structure;

14

a first material mounted within the slow wave structure between the input port and the output port; and
 a second material, wherein the slow wave structure is configured to receive a radio frequency signal through the input port and to output an amplified radio frequency signal through the output port, wherein the radio frequency signal has an operational frequency; and
 an electron beam vacuum tube configured to receive an electron beam and to focus the electron beam for transmission therethrough, wherein the electron beam vacuum tube is mounted to extend lengthwise through a center of the slow wave structure defined in a plane perpendicular to a direction of propagation of the electron beam,

wherein the second material is mounted in the first material at periodic intervals in a direction of propagation of the radio frequency signal between the input port and the output port, and the second material has a real part of permittivity that is negative and a real part of permeability that is positive at the operational frequency.

9. The traveling wave tube of claim 8, wherein the slow wave structure is a helical coil formed by the first material and the second material, and the second material is mounted across at least a portion of a cross section of the helical coil.

10. The traveling wave tube of claim 8, wherein the first material is vacuum.

11. The traveling wave tube of claim 10, wherein the slow wave structure is a folded waveguide having a cross section perpendicular to the direction of propagation of the radio frequency signal.

12. The traveling wave tube of claim 11, wherein the second material is mounted across at least a portion of the cross section of the folded waveguide.

13. The traveling wave tube of claim 12, wherein the folded waveguide is a serpentine folded waveguide.

14. The traveling wave tube of claim 13, wherein the second material forms a wedge.

15. The traveling wave tube of claim 12, wherein the second material is mounted at a maximum distance from the center of the slow wave structure.

16. The traveling wave tube of claim 12, wherein the second material is a metal plate that extends across the portion of the cross section of the folded waveguide.

17. The traveling wave tube of claim 16, wherein the cross section is rectangular and the metal plate extends lengthwise between longer sides of the rectangular cross section and only partially lengthwise between shorter sides of the rectangular cross section.

18. The traveling wave tube of claim 12, wherein the second material is a plurality of metal wires that extend lengthwise across the portion of the cross section of the folded waveguide.

19. The traveling wave tube of claim 18, wherein the cross section is rectangular and the plurality of metal wires extend lengthwise between longer sides of the rectangular cross section.

20. The traveling wave tube of claim 8, wherein the second material provides a shunt inductive load to the slow wave structure.

* * * * *