



(19) **United States**

(12) **Patent Application Publication** (10) **Pub. No.: US 2023/0352997 A1**

Severson et al.

(43) **Pub. Date: Nov. 2, 2023**

(54) **BEARINGLESS ELECTRICAL MACHINES WITH REDUCED NUMBER OF INVERTERS**

(52) **U.S. Cl.**
CPC **H02K 1/2796** (2022.01); **H02K 3/28** (2013.01); **H02K 7/09** (2013.01)

(71) Applicant: **Wisconsin Alumni Research Foundation**, Madison, WI (US)

(57) **ABSTRACT**

(72) Inventors: **Eric Loren Severson**, Middleton, WI (US); **Zhouzhou Wang**, Fitchburg, WI (US)

A machine system includes a shaft, a first rotor, a first stator, a second rotor, a second stator, a first, first-phase coil and a second, first-phase coil of a first stator winding, a first, second-phase coil and a second, second-phase coil of a second stator winding, and a first, third-phase coil and a second, third-phase coil of a third stator winding wound about the first stator, a first, first-phase coil and a second, first-phase coil of a fourth stator winding, a first, second-phase coil and a second, second-phase coil of a fifth stator winding, and a first, third-phase coil and a second, third-phase coil of a sixth stator winding wound about the second stator, and an inverter drive system. The stator windings are configured to provide a torque and a suspension force under control of an inverter drive system consisting of only three inverters.

(21) Appl. No.: **17/734,519**

(22) Filed: **May 2, 2022**

Publication Classification

(51) **Int. Cl.**
H02K 1/2796 (2006.01)
H02K 3/28 (2006.01)

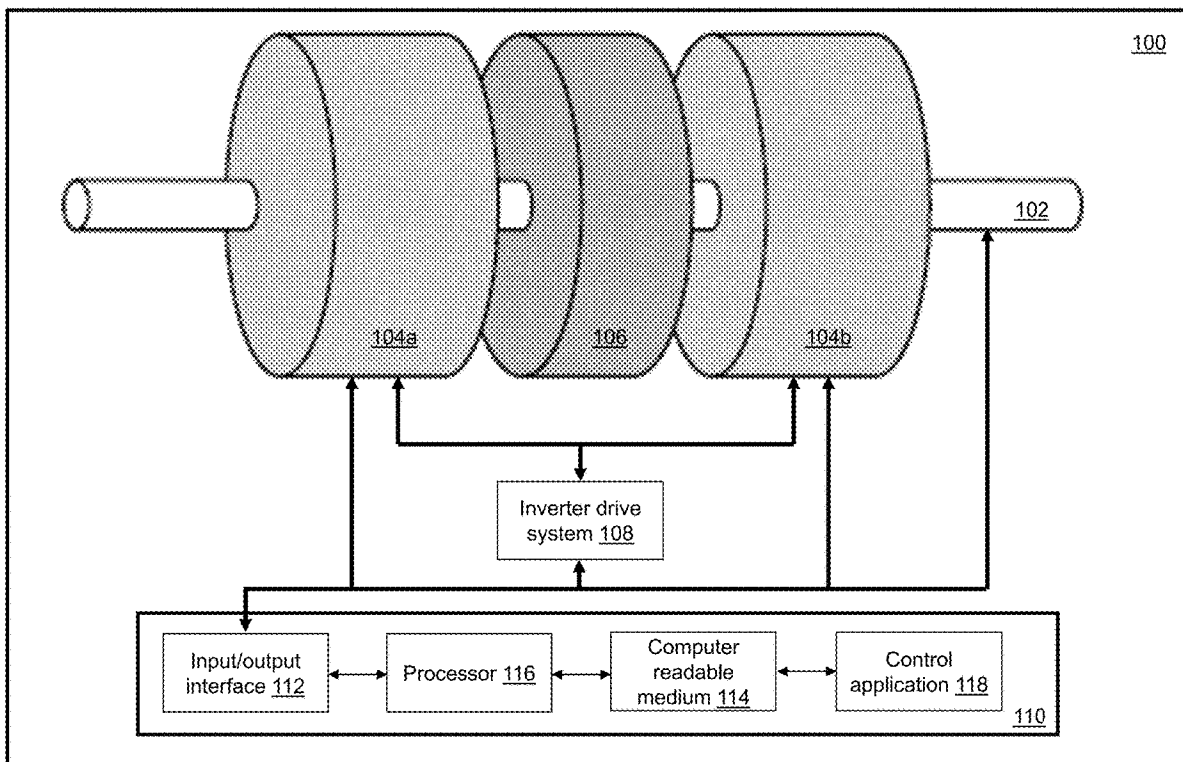

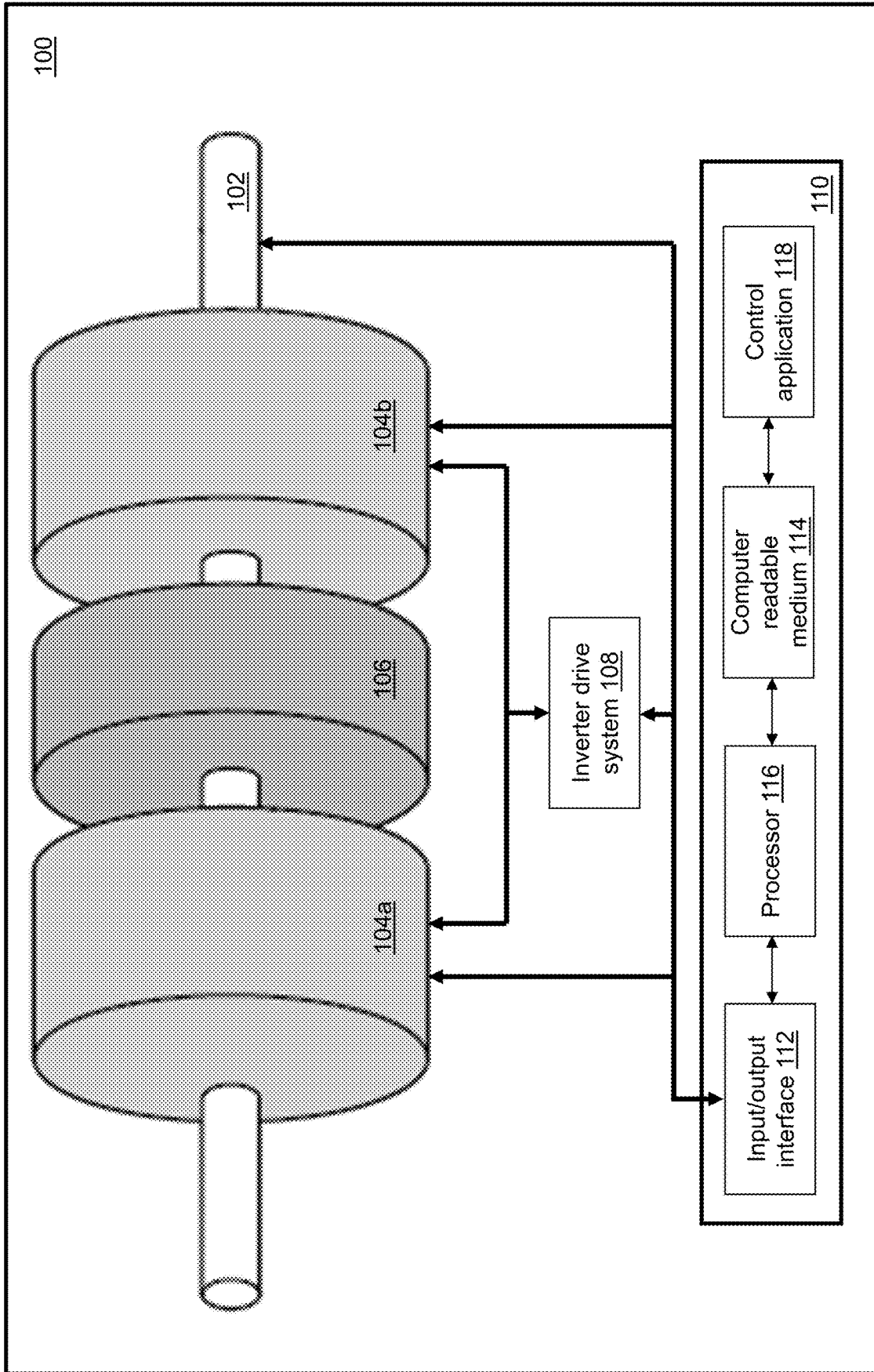

FIG. 1

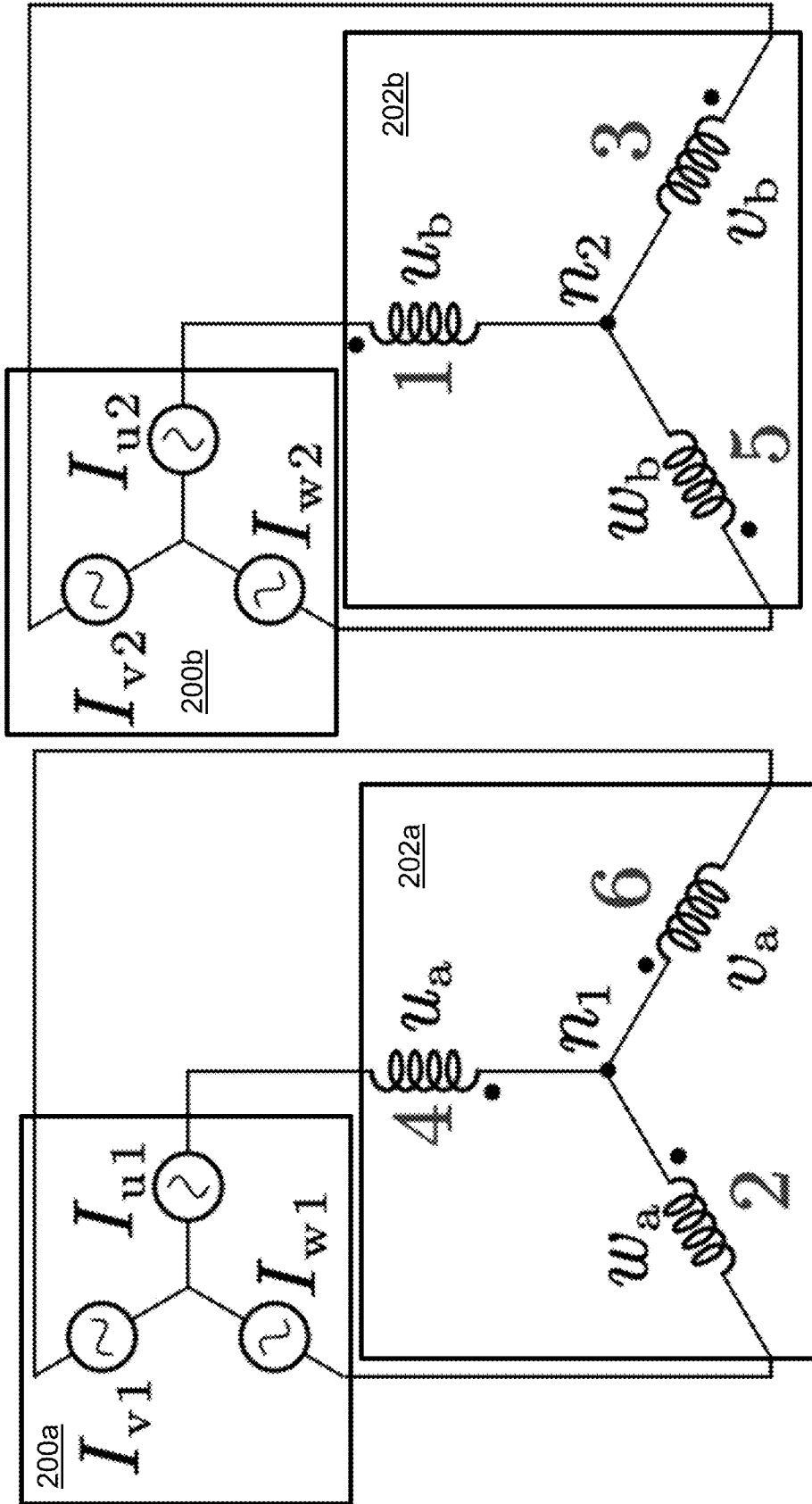

FIG. 2A

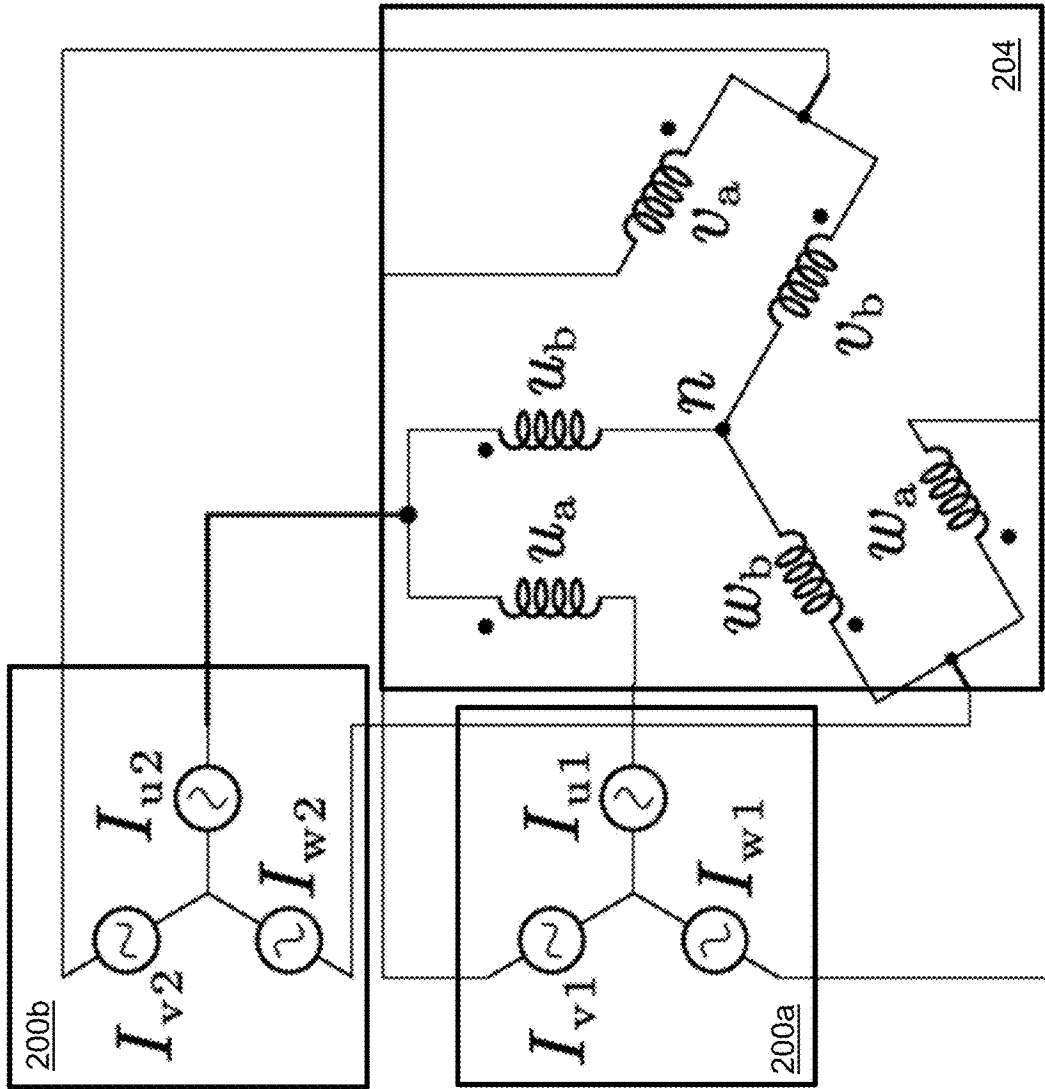

FIG. 2B

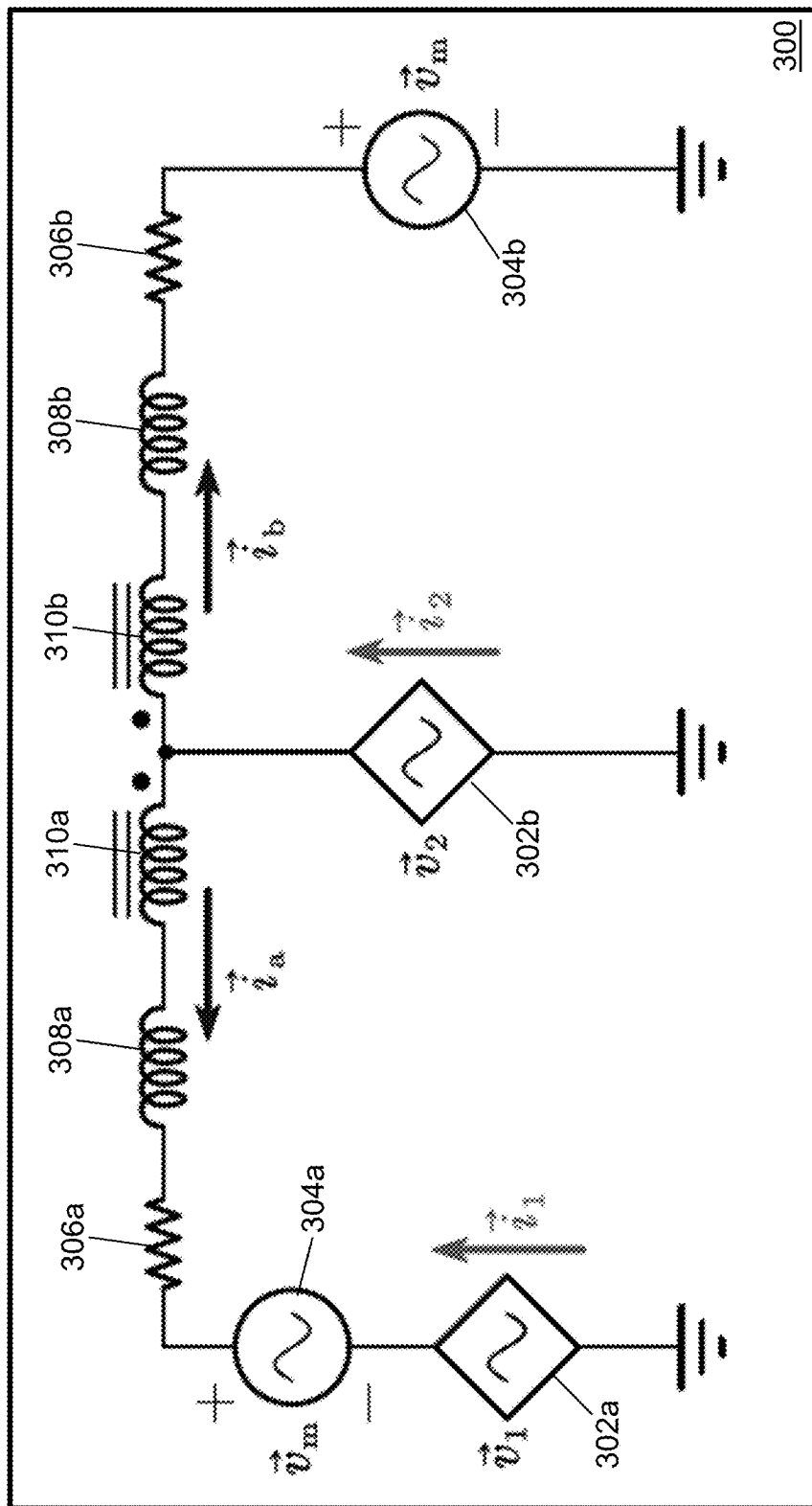

FIG. 3

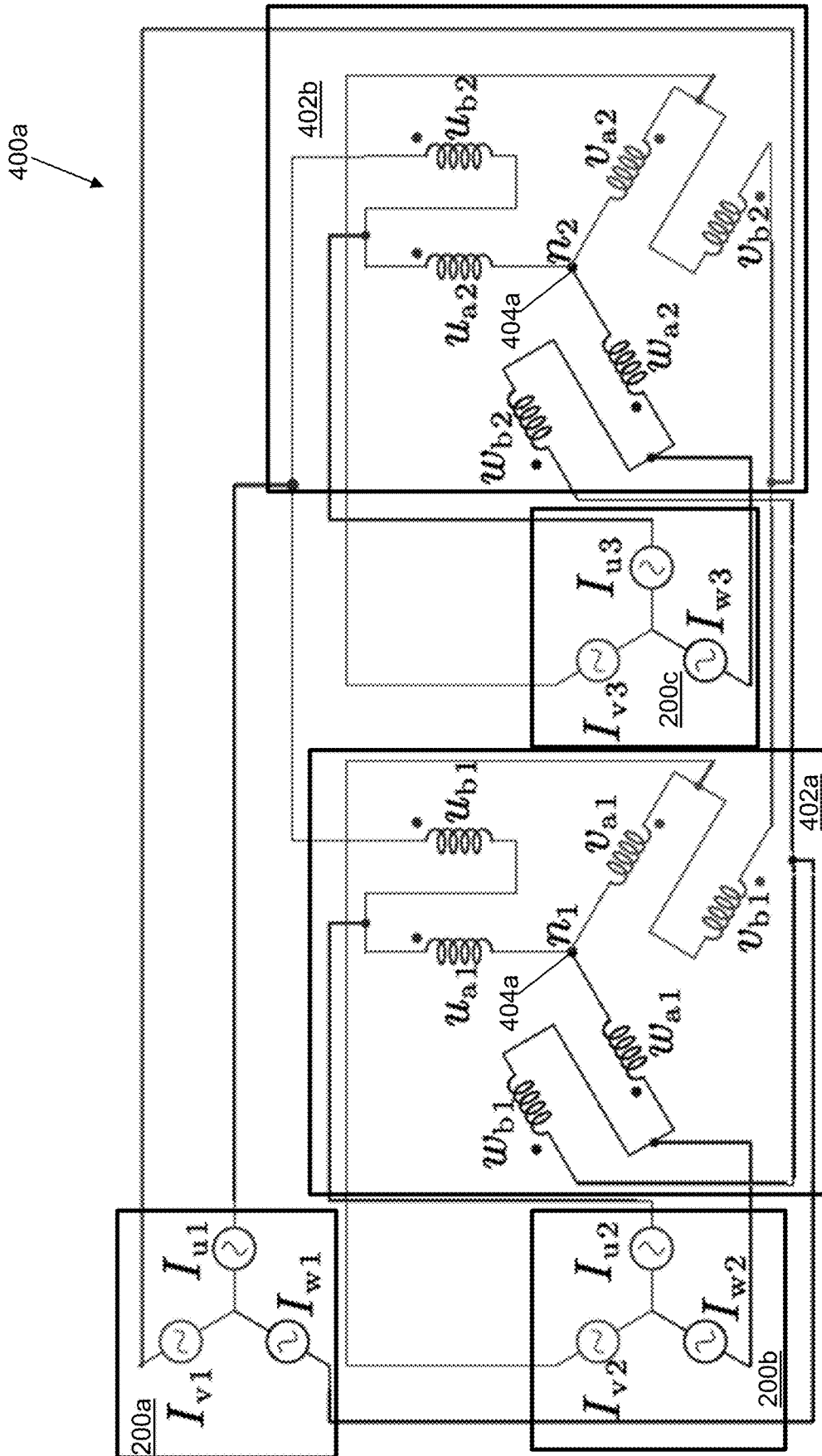

FIG. 4A

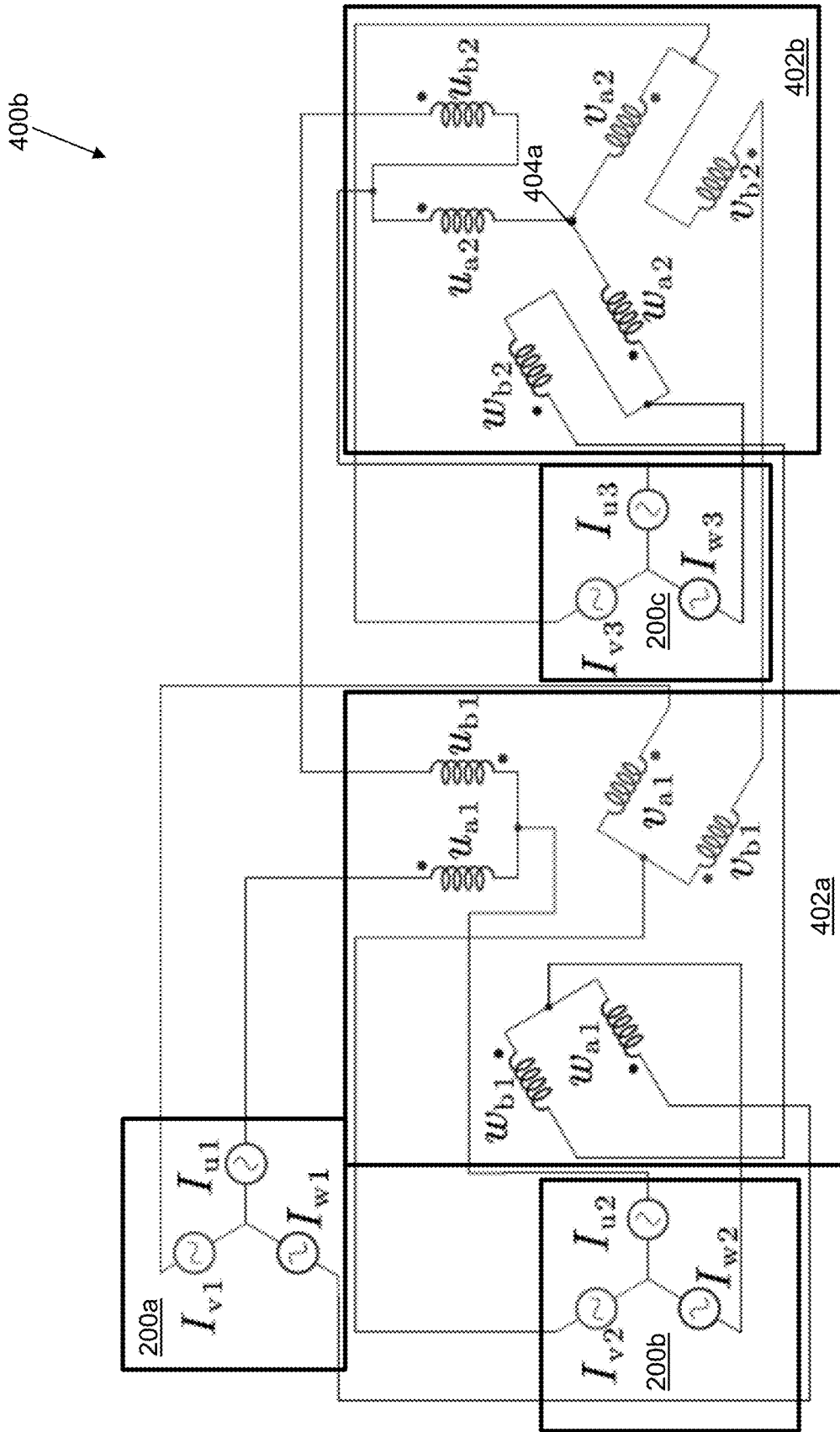

FIG. 4B

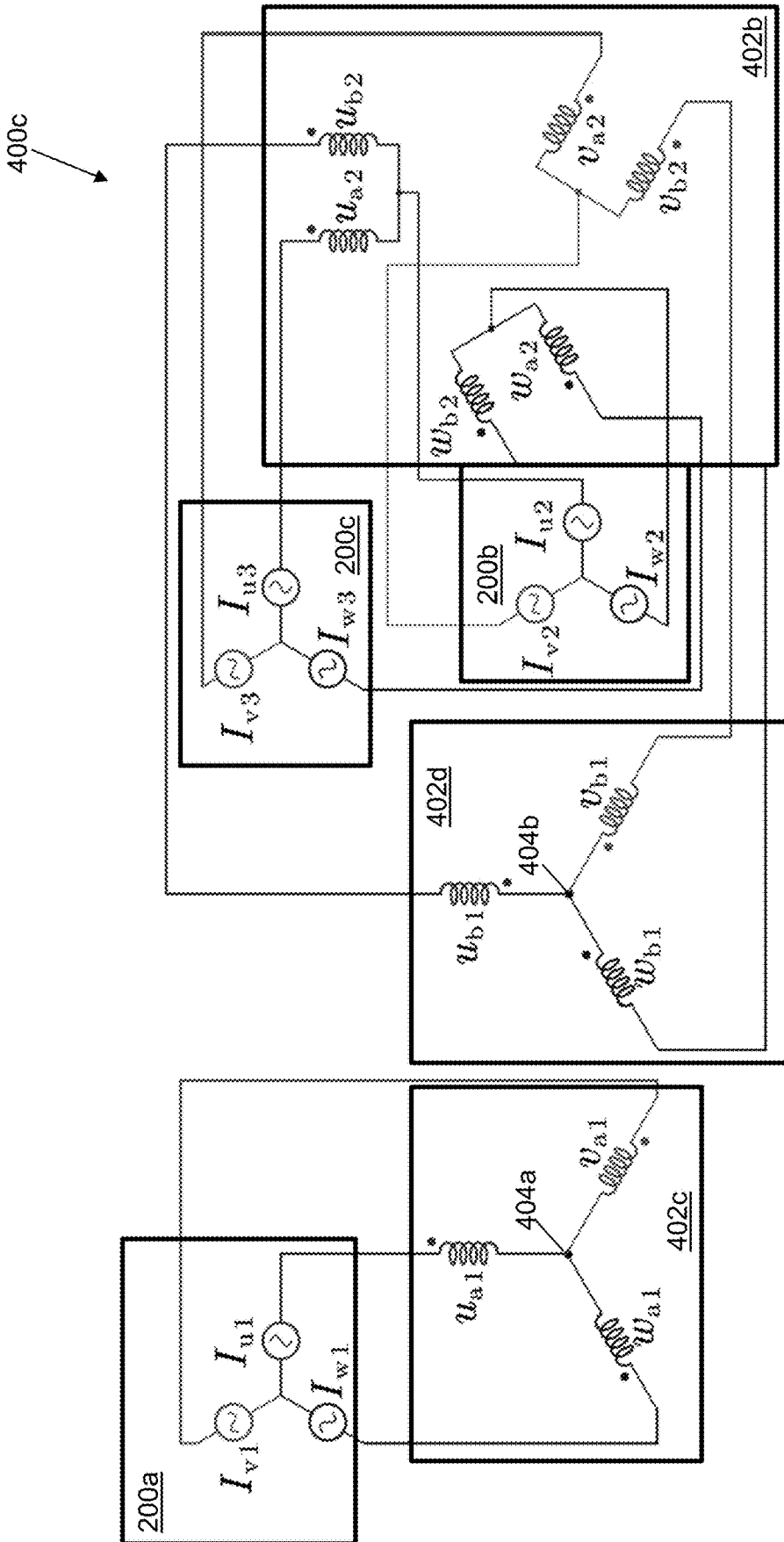

FIG. 4C

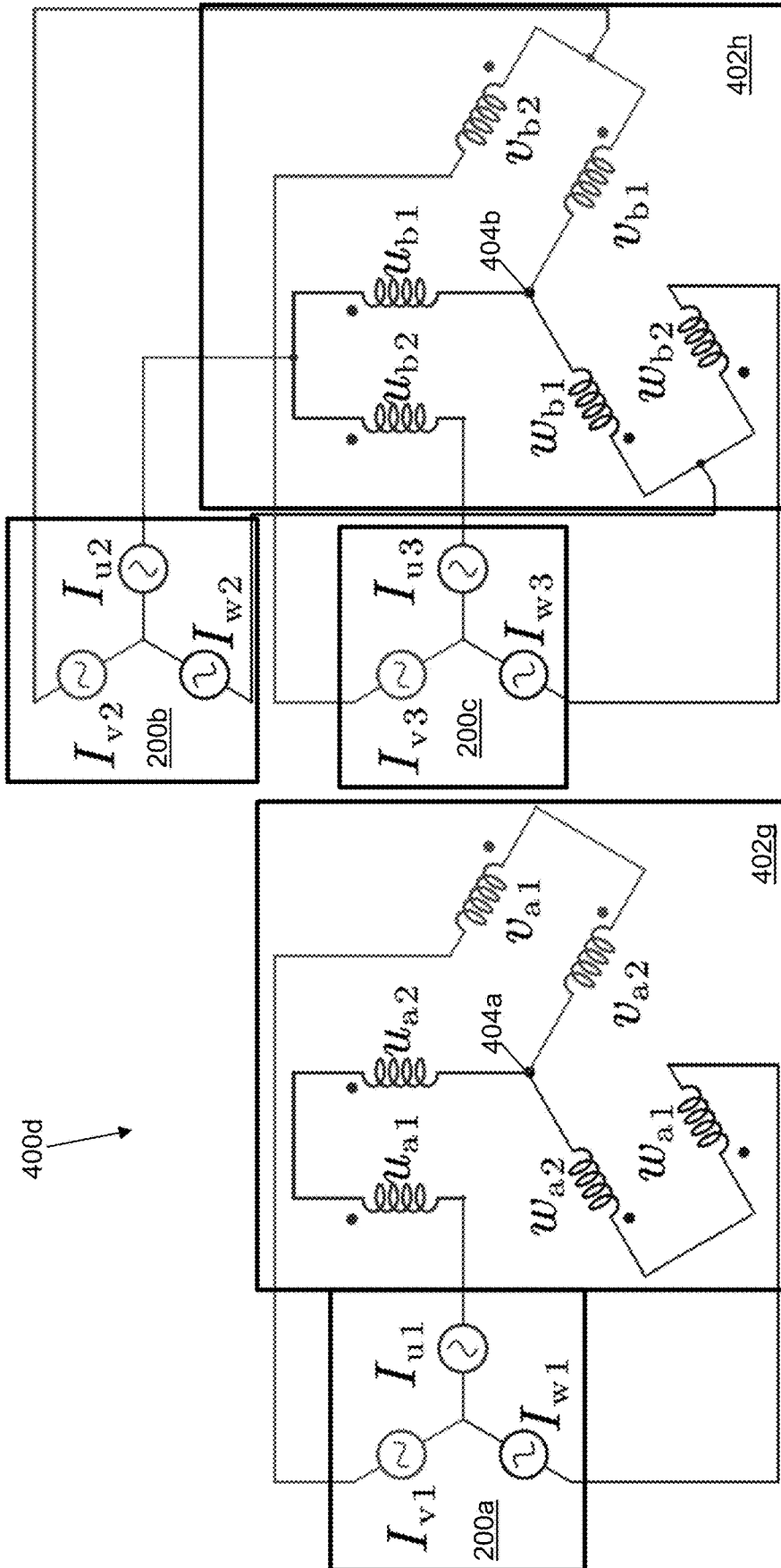

FIG. 4D

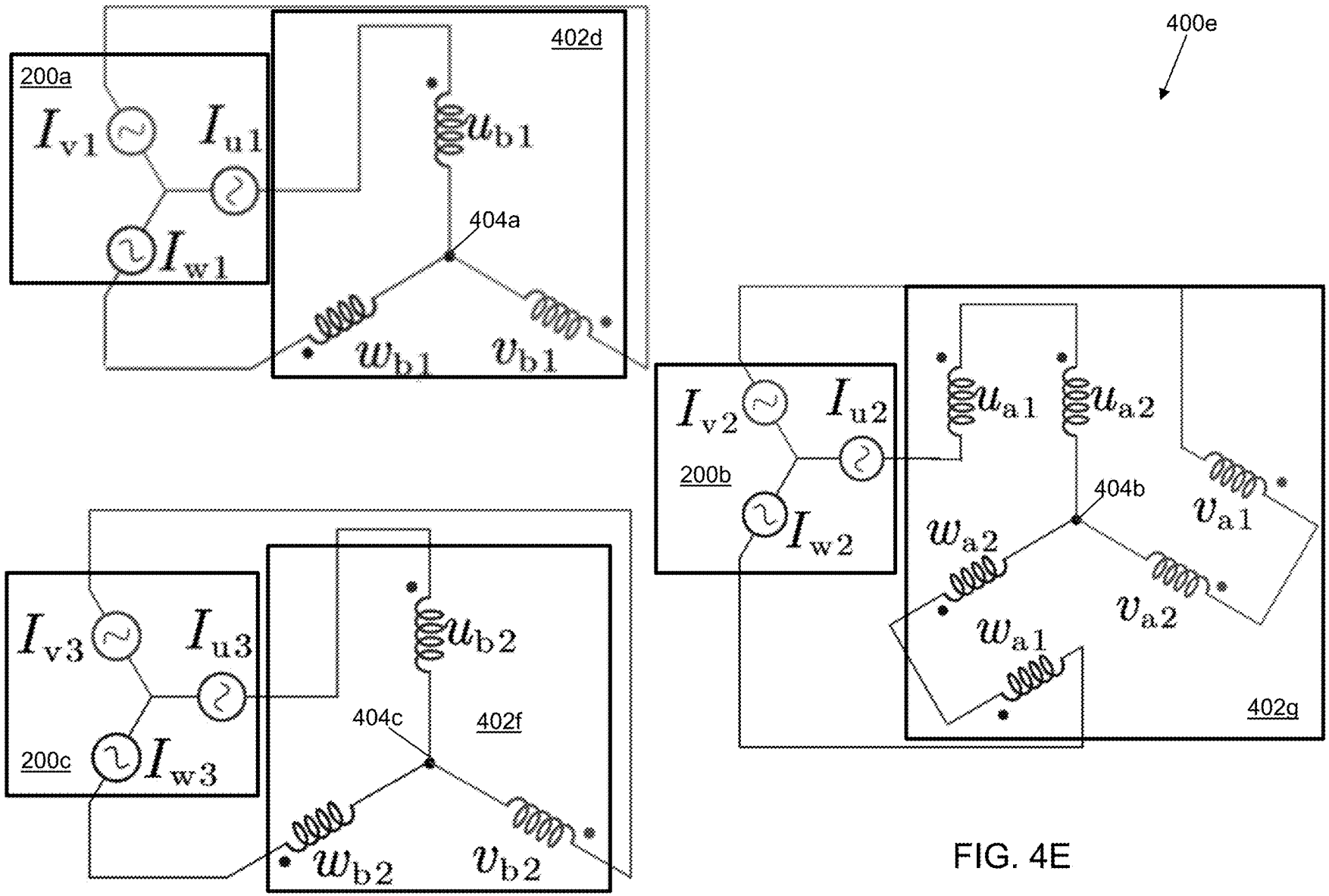

FIG. 4E

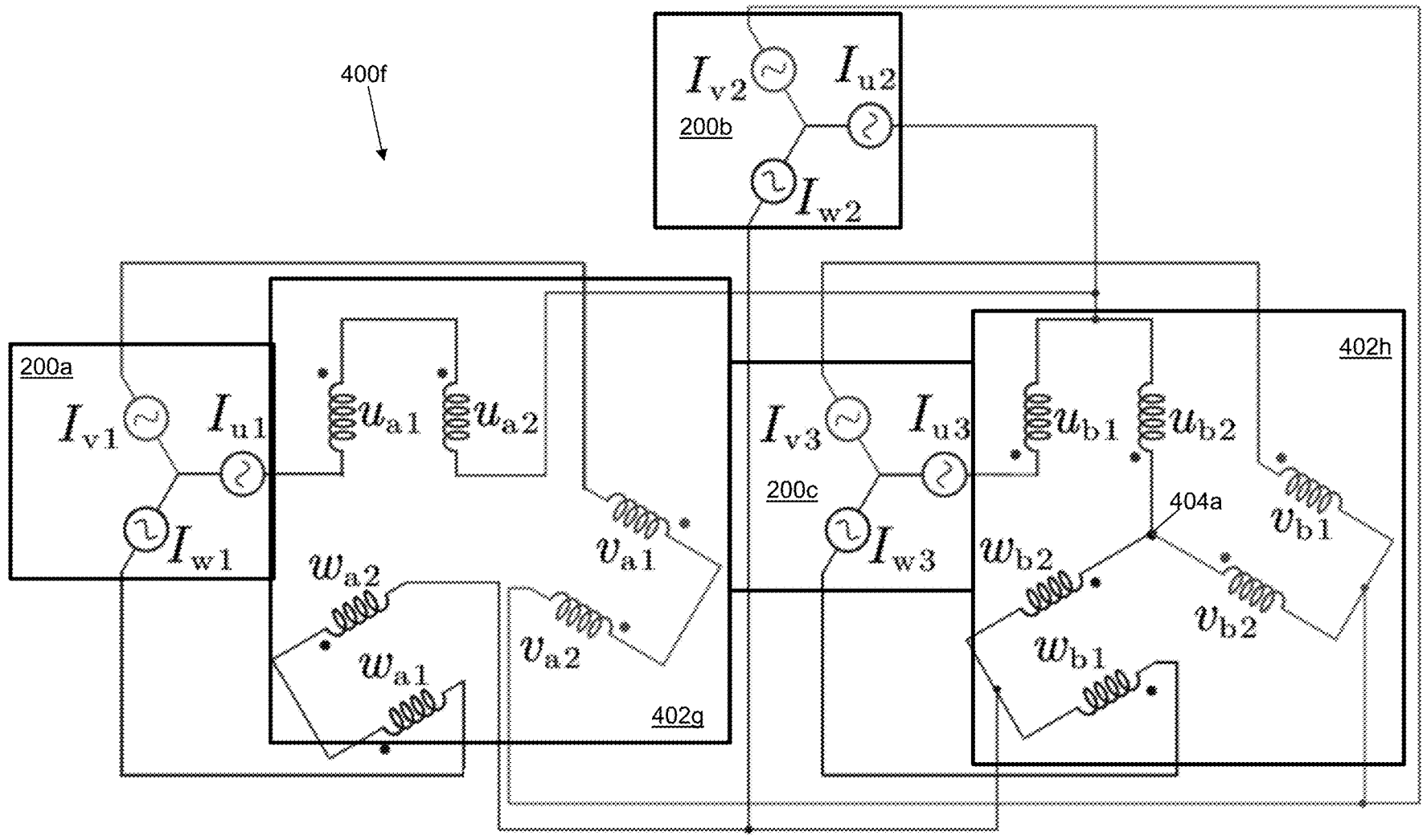
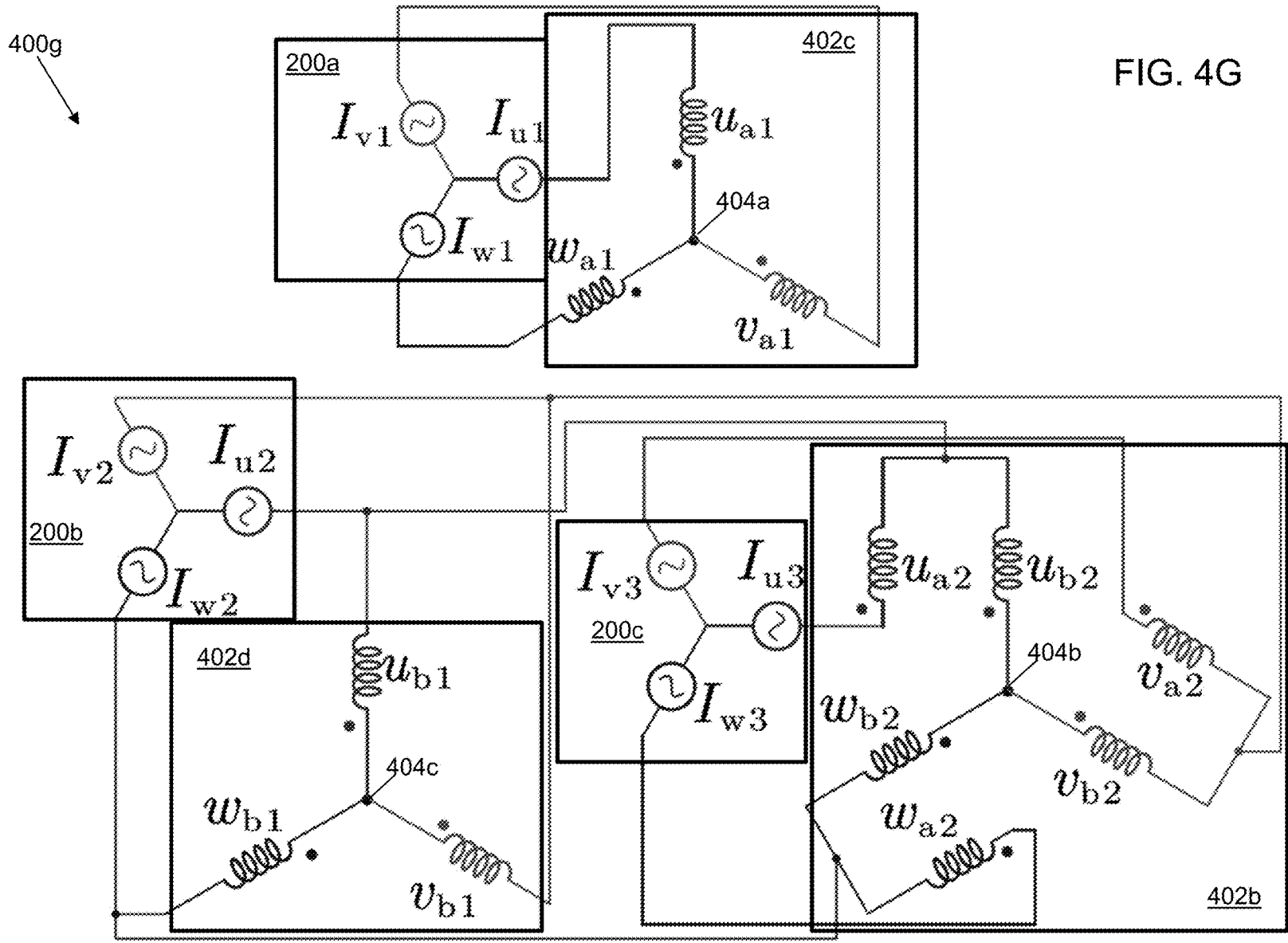

FIG. 4F

FIG. 4G



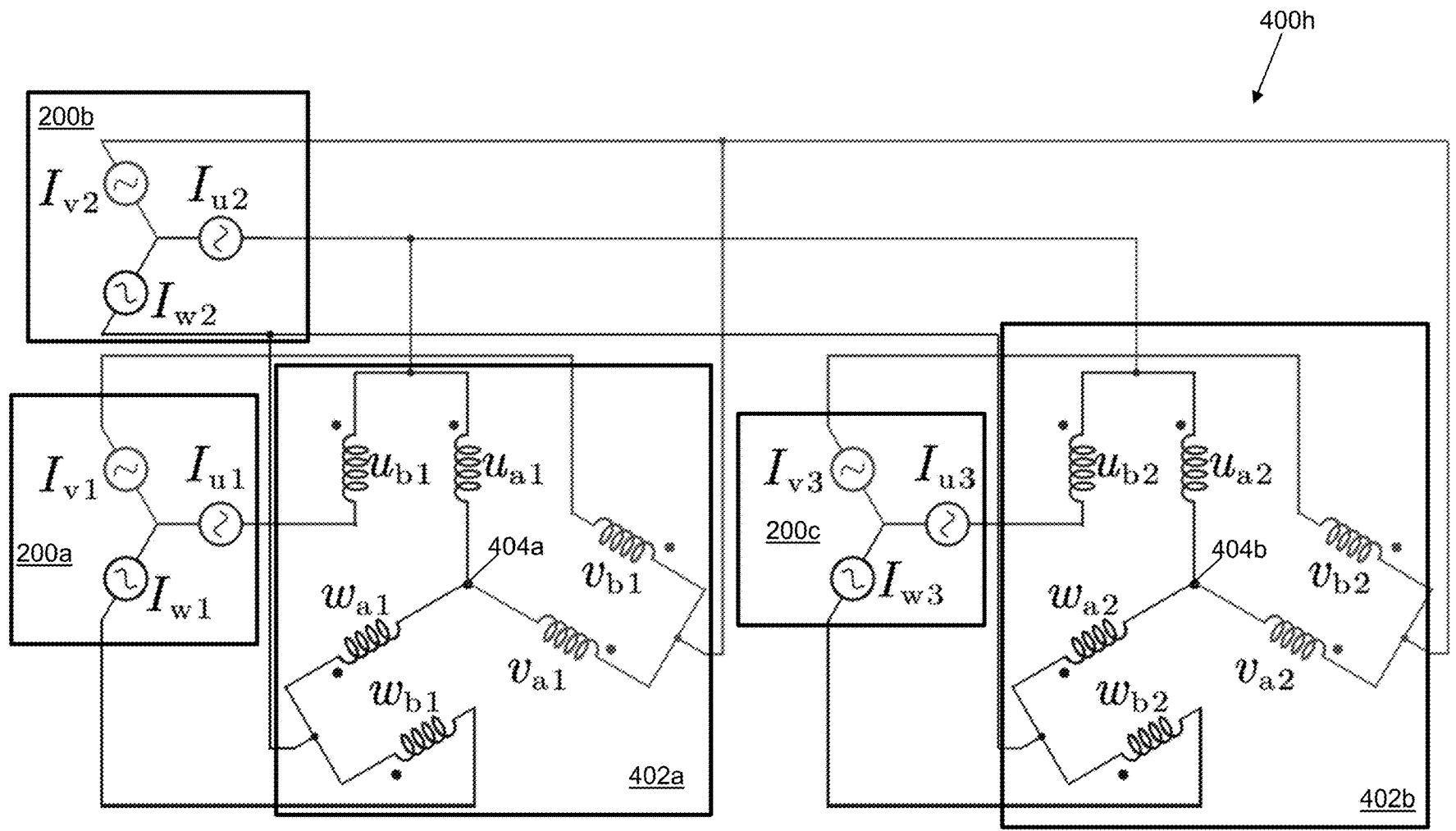

FIG. 4H

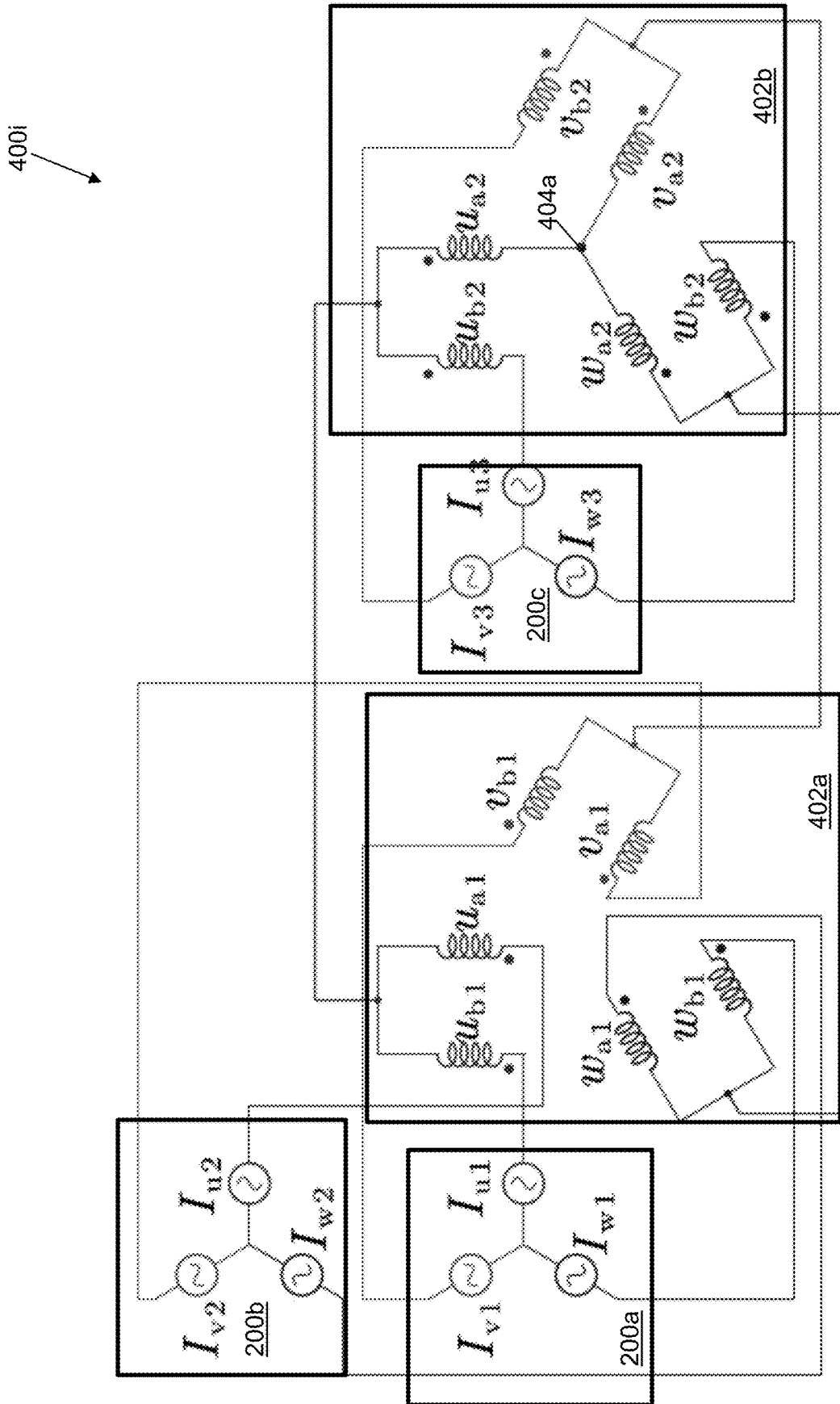

FIG. 4I

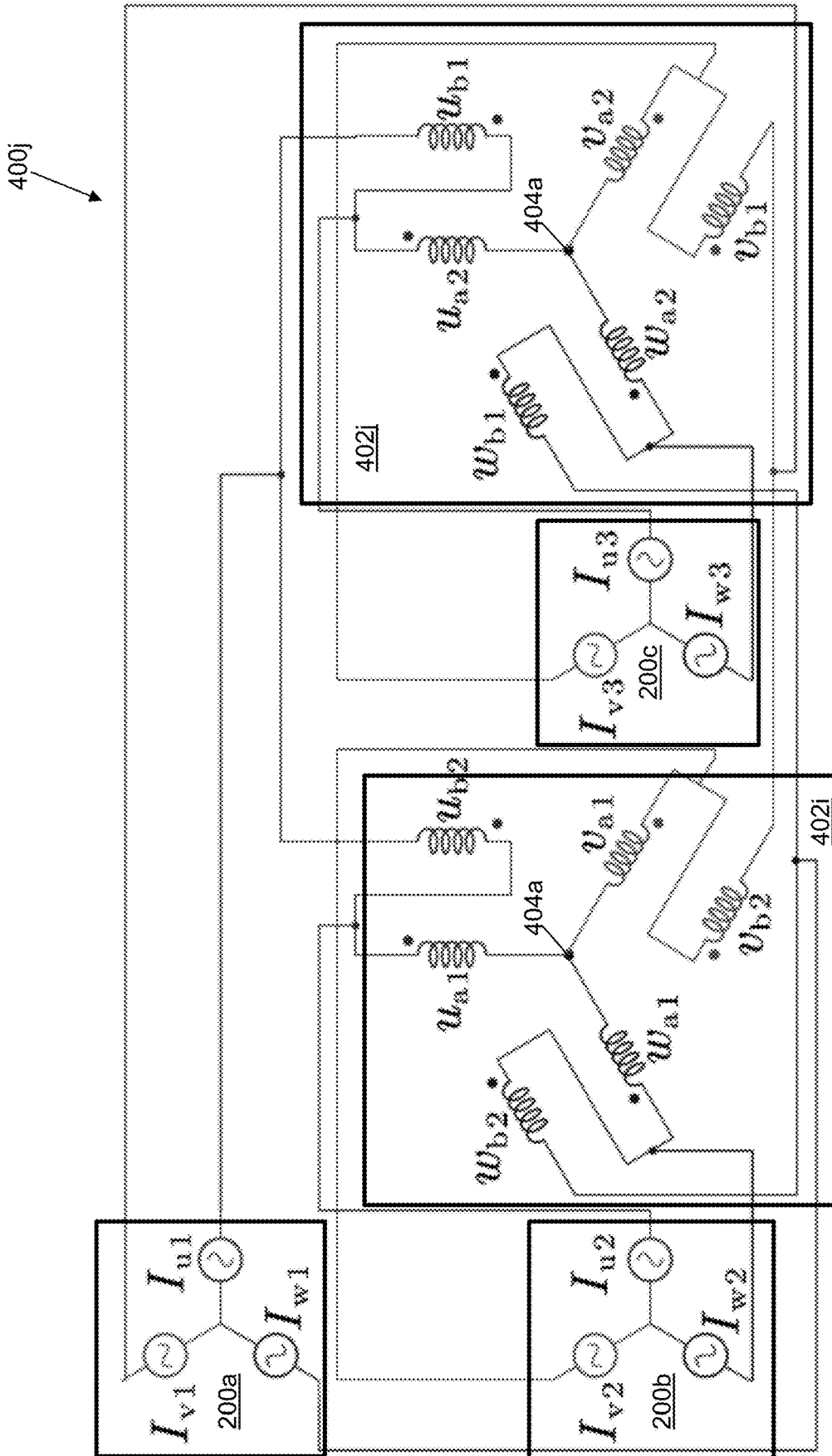

FIG. 4J

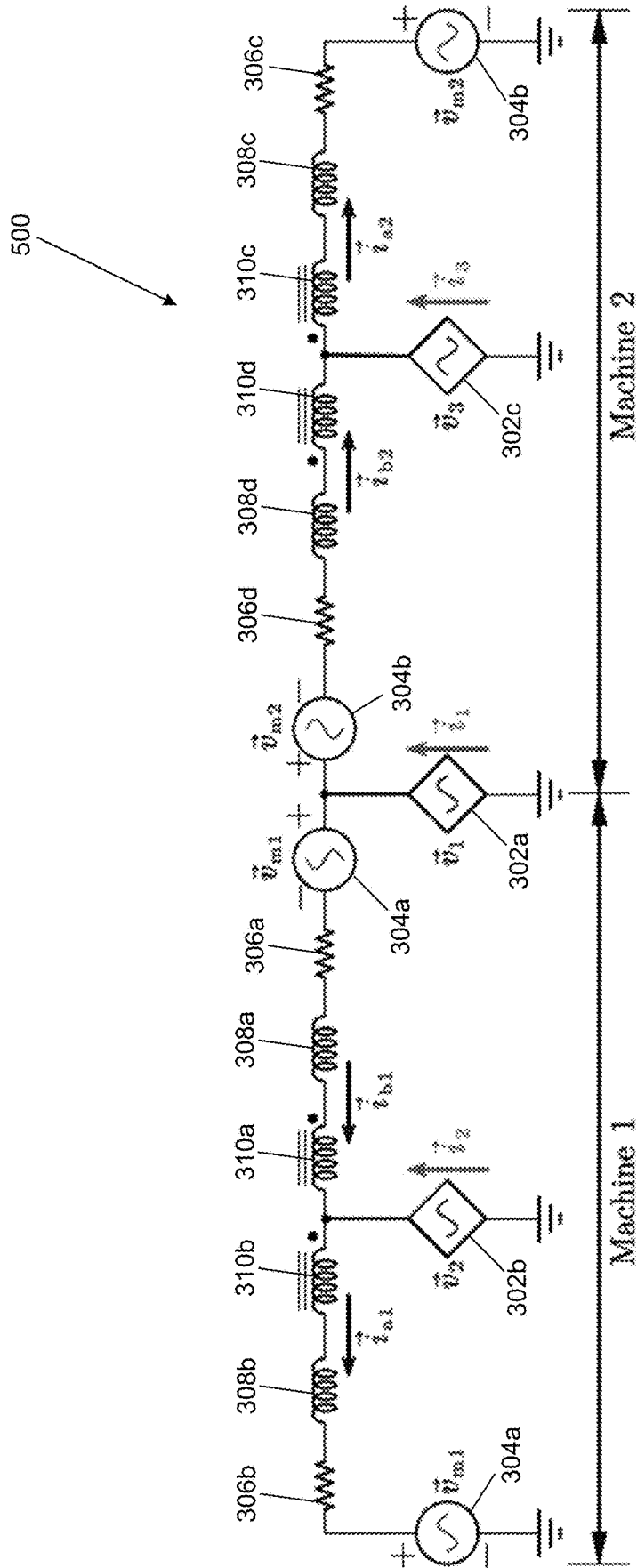

FIG. 5

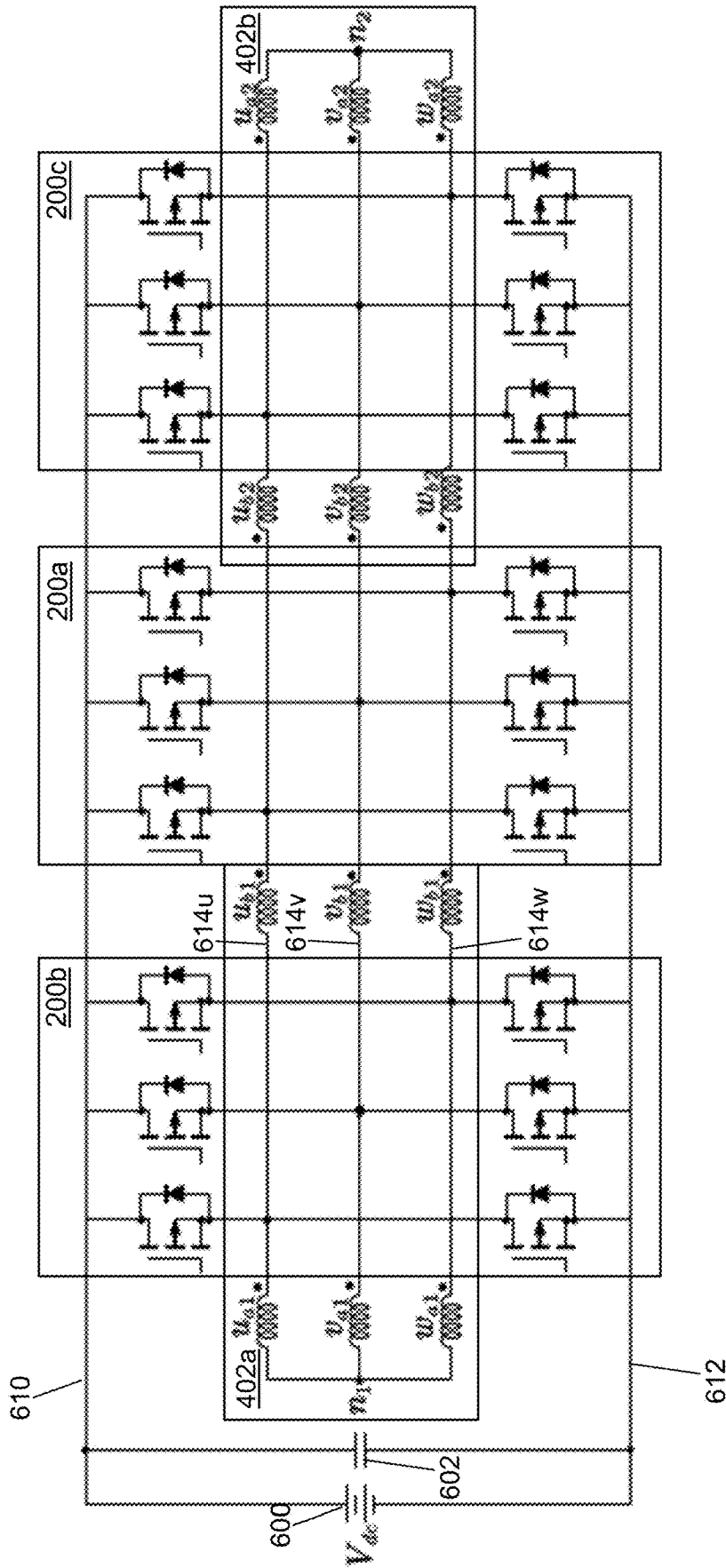

FIG. 6A

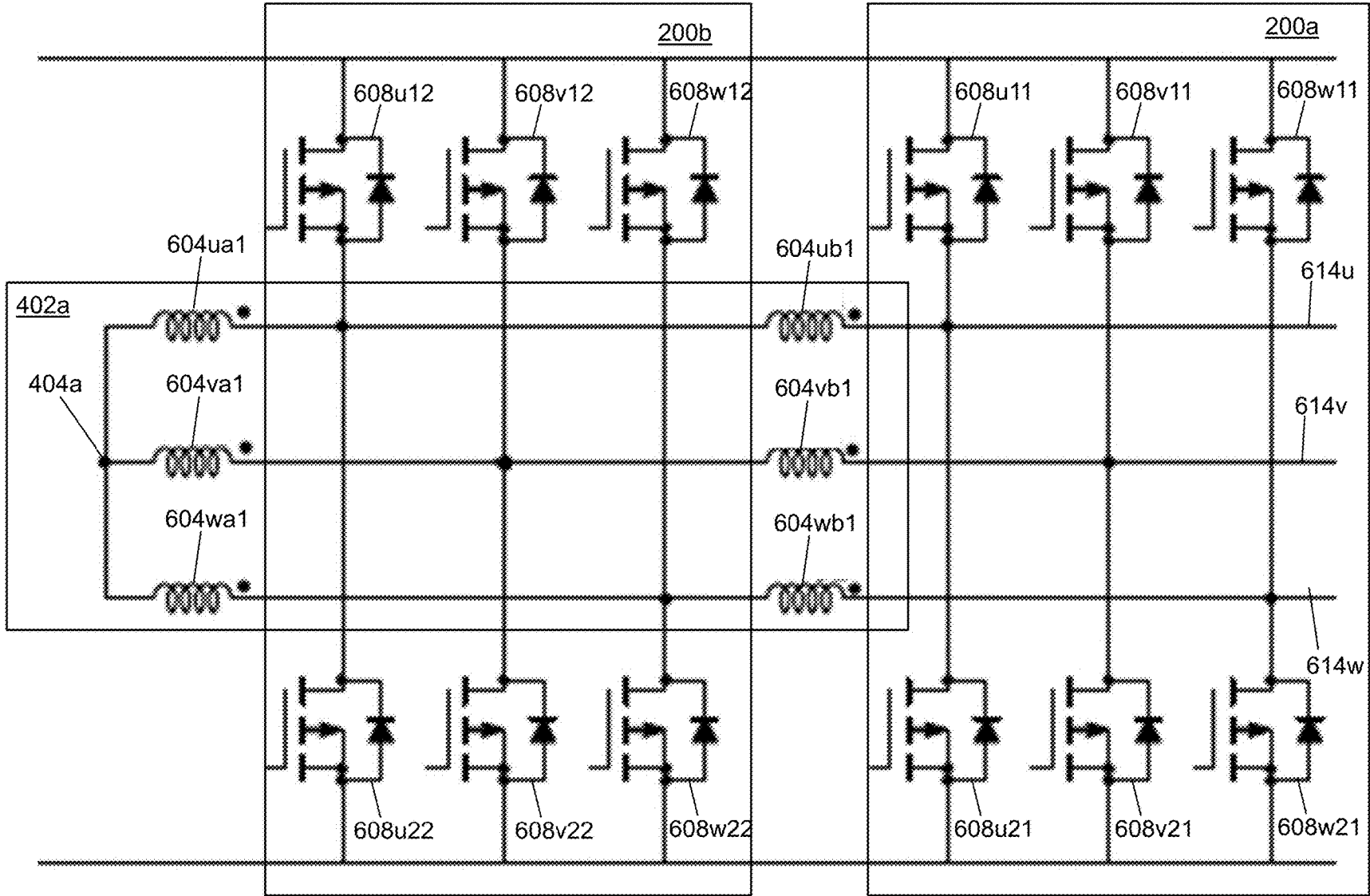

FIG. 6B

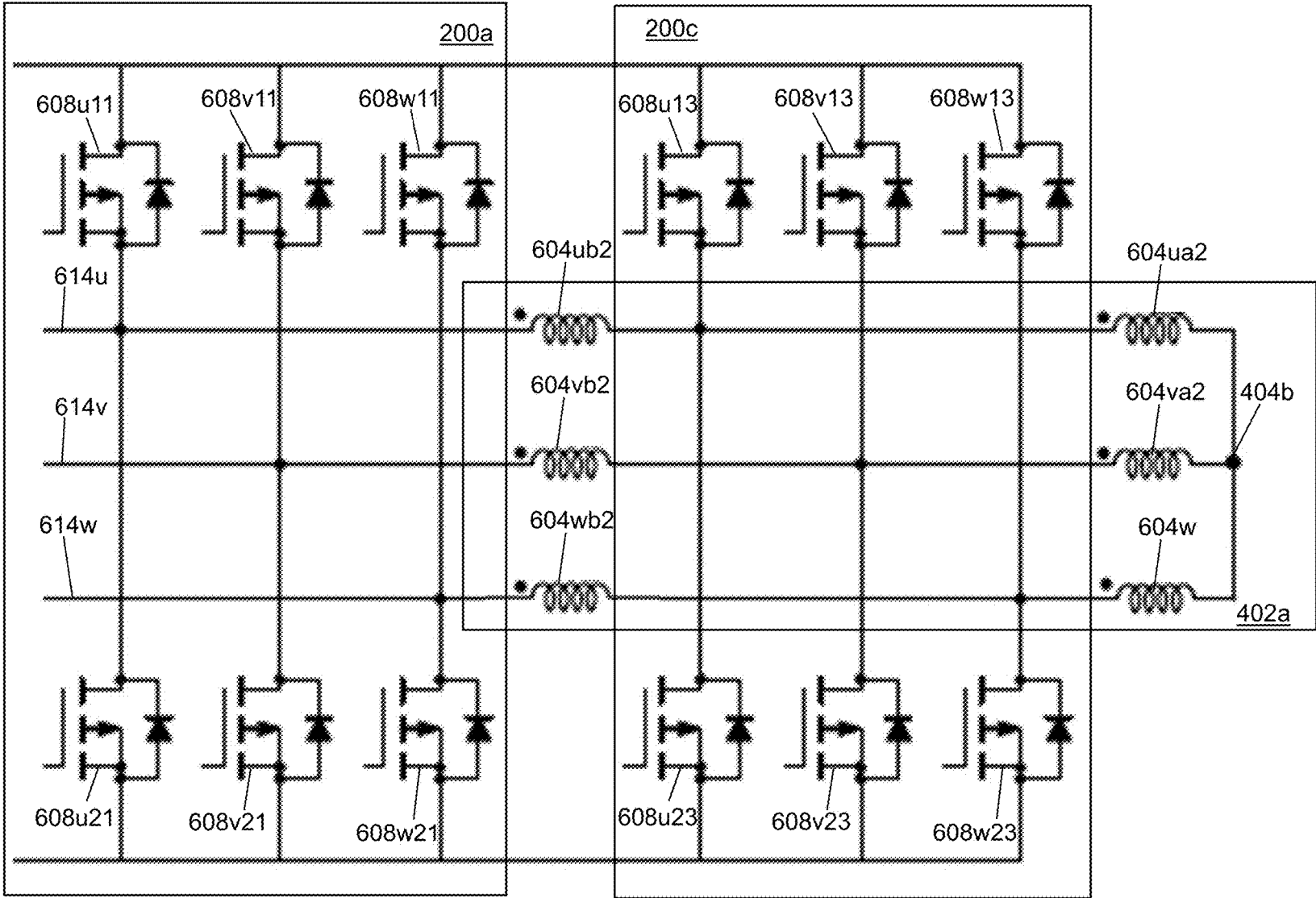

FIG. 6C

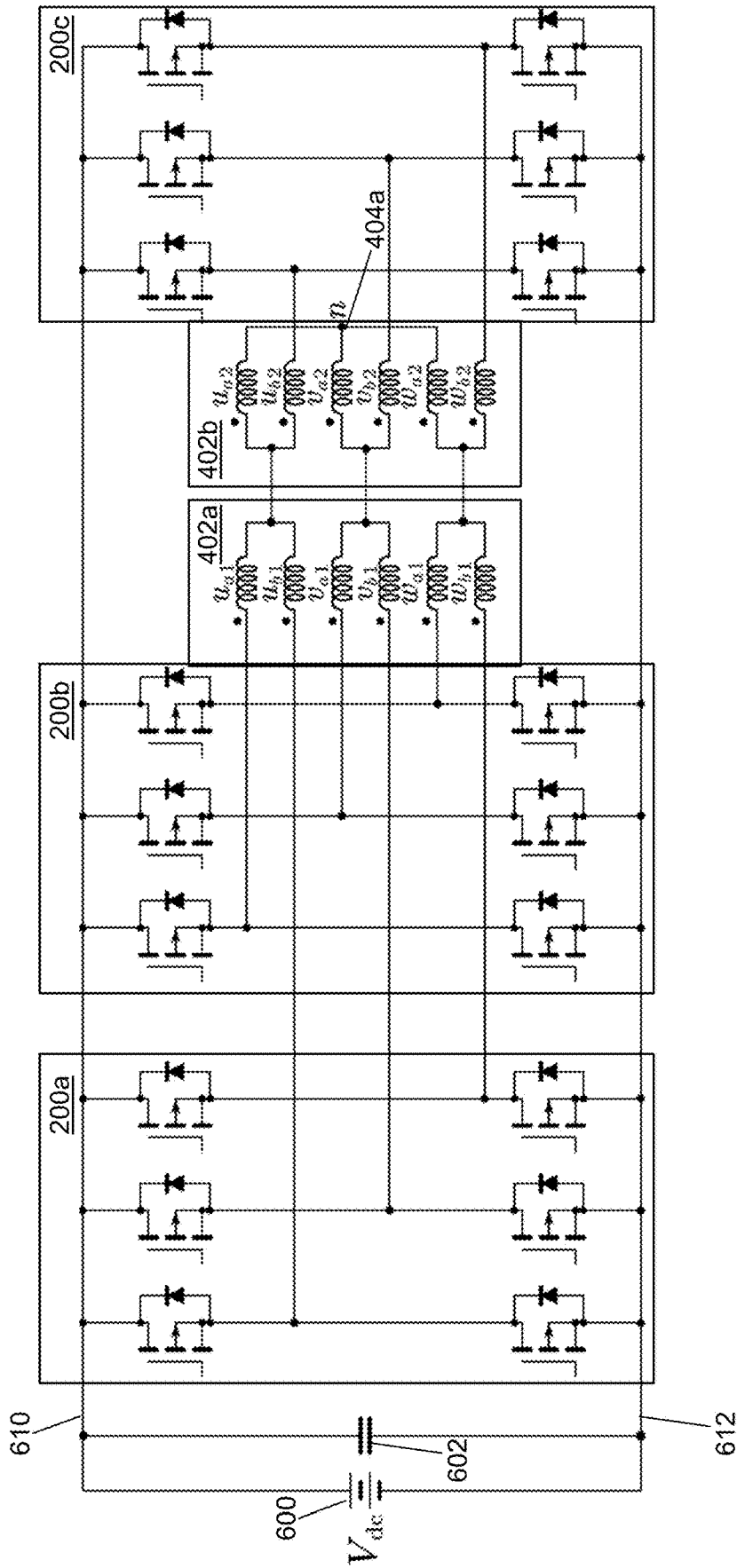
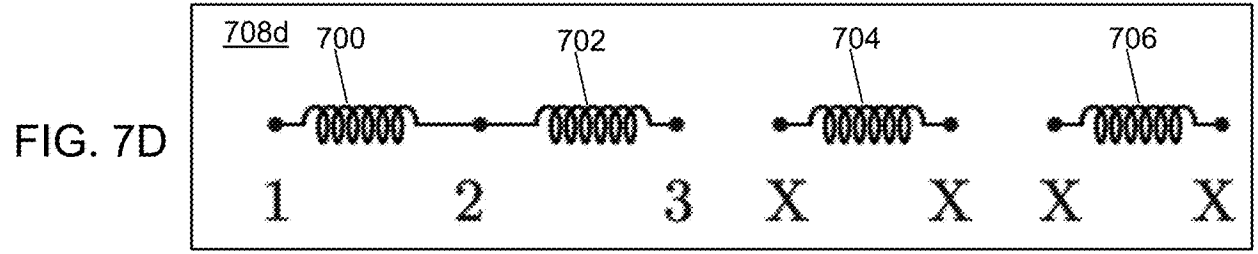
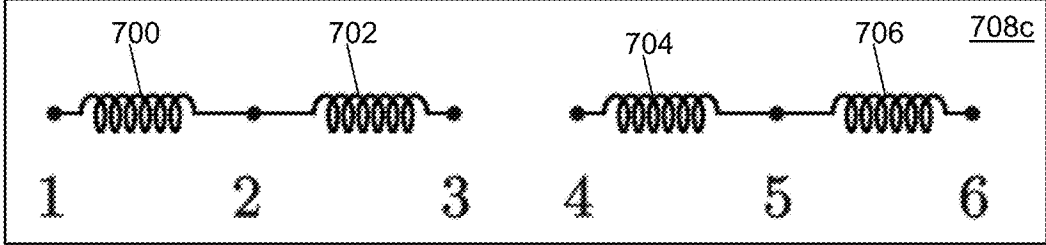
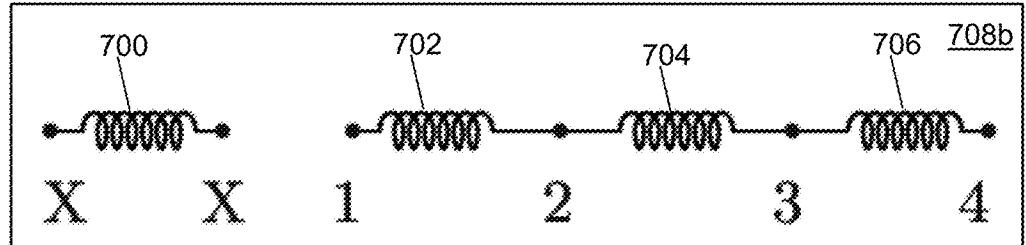
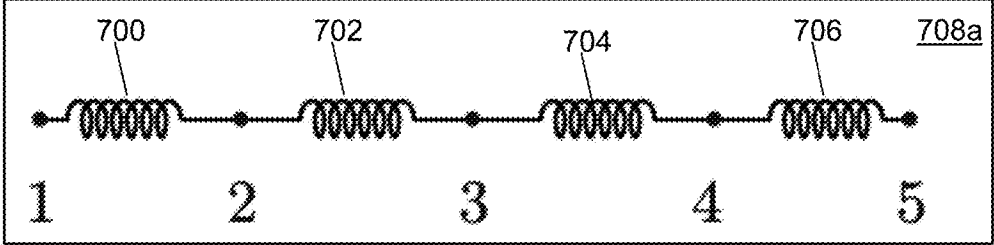

FIG. 6D



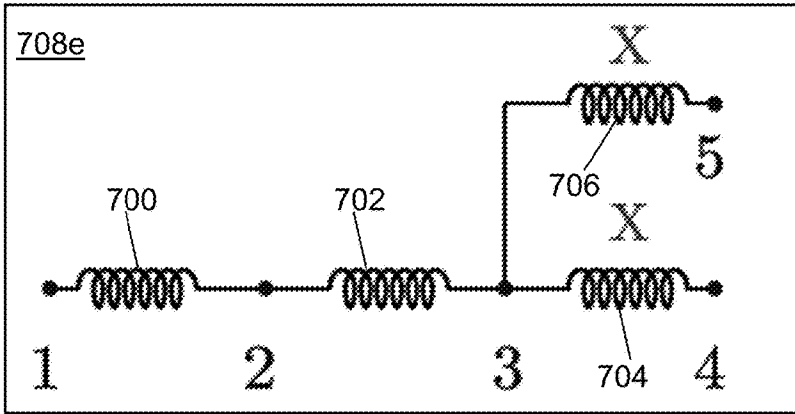

FIG. 7E

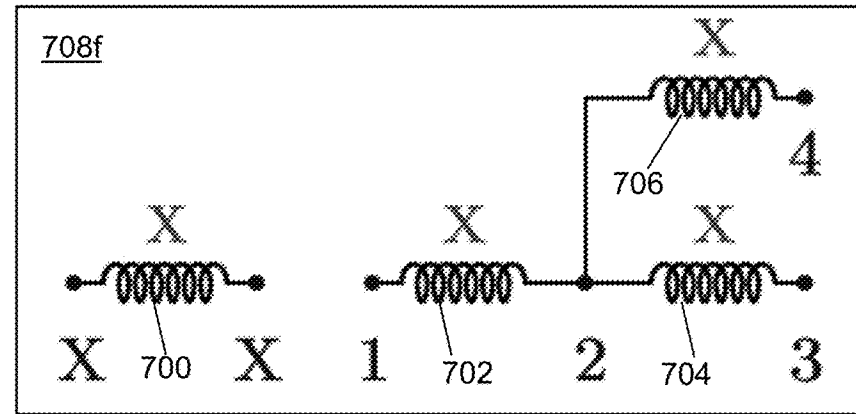

FIG. 7F

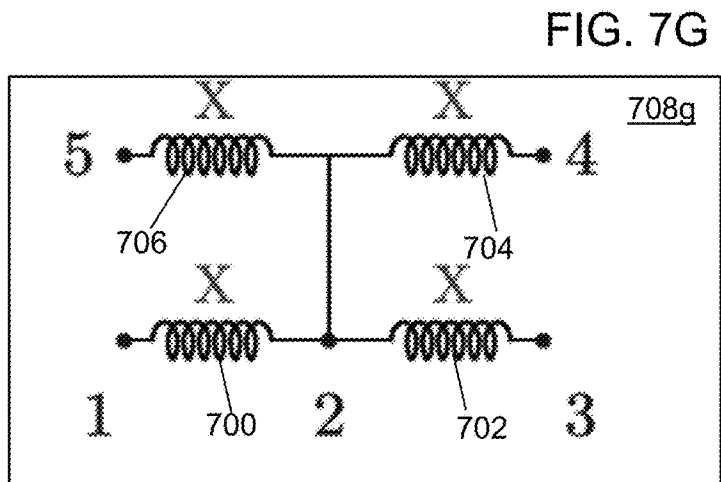

FIG. 7G

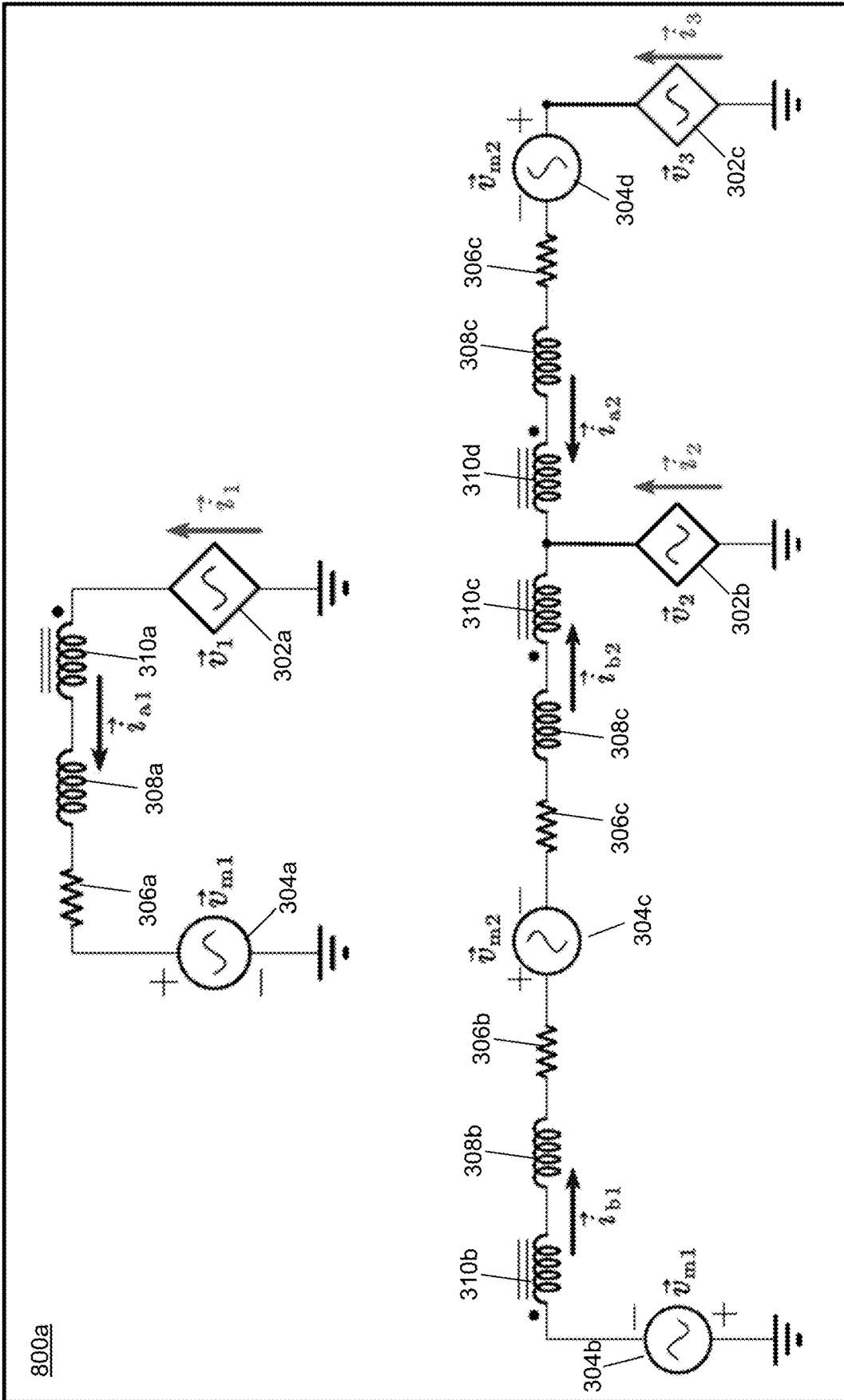

FIG. 8A

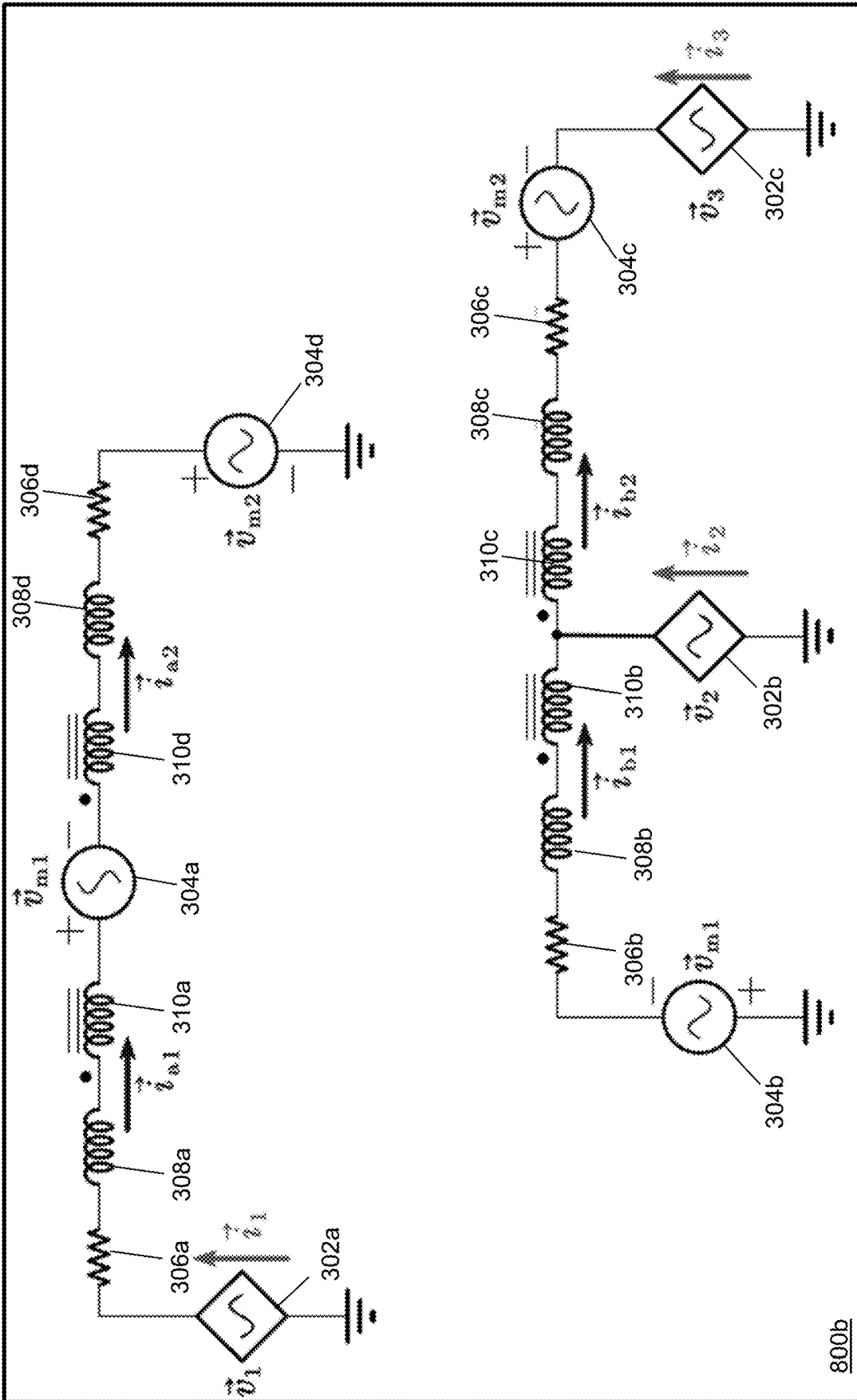

FIG. 8B

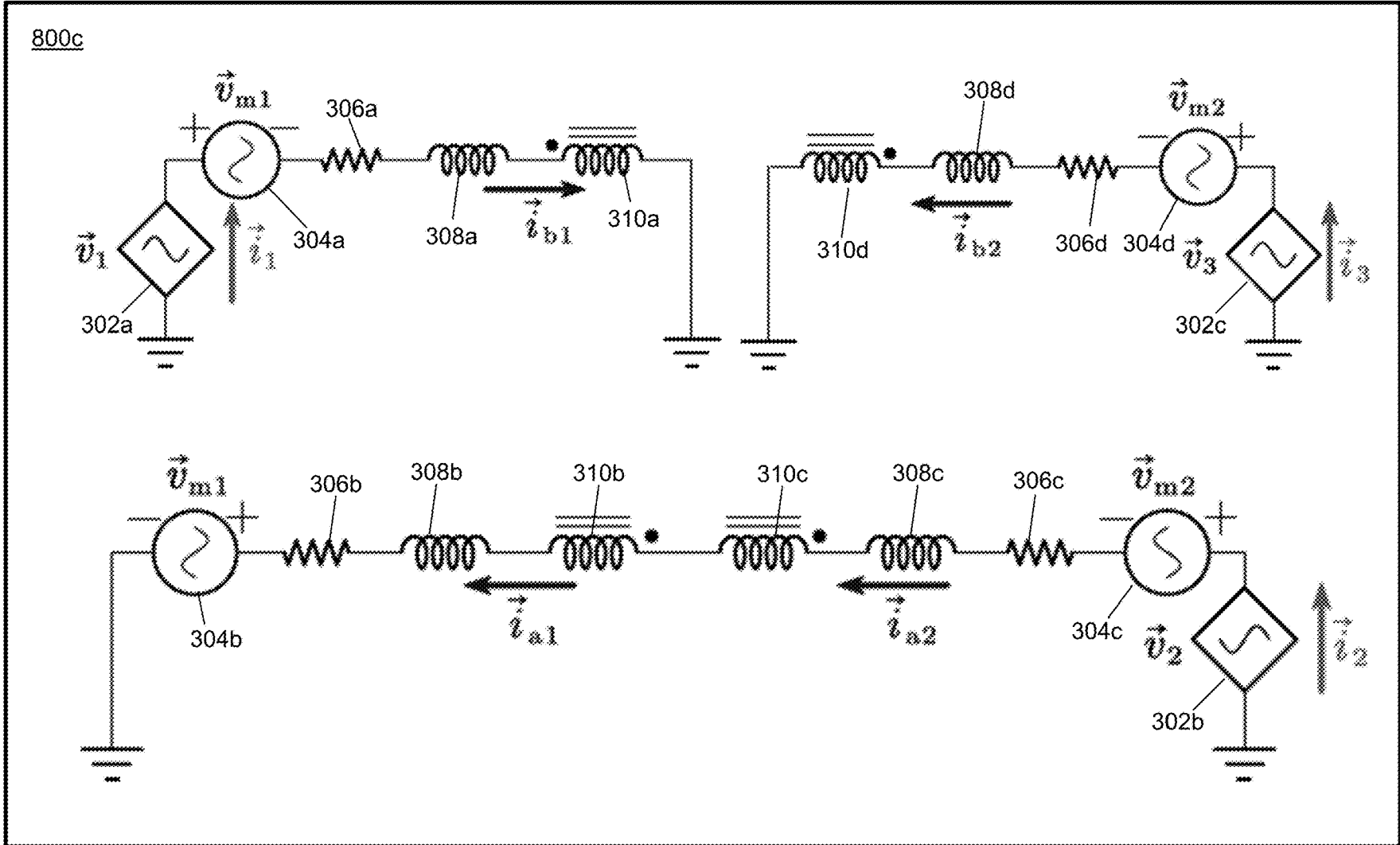

FIG. 8C

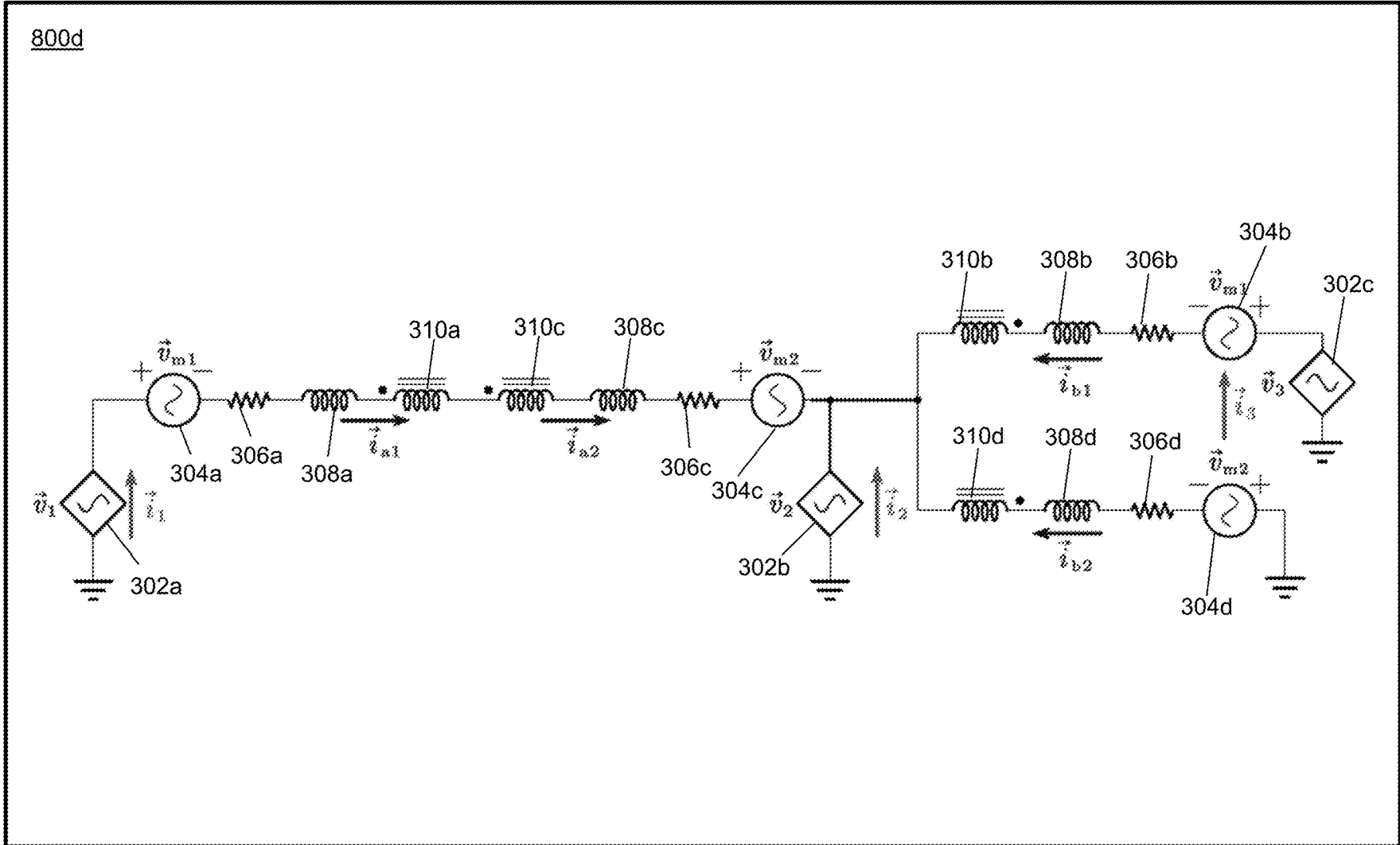

FIG. 8D

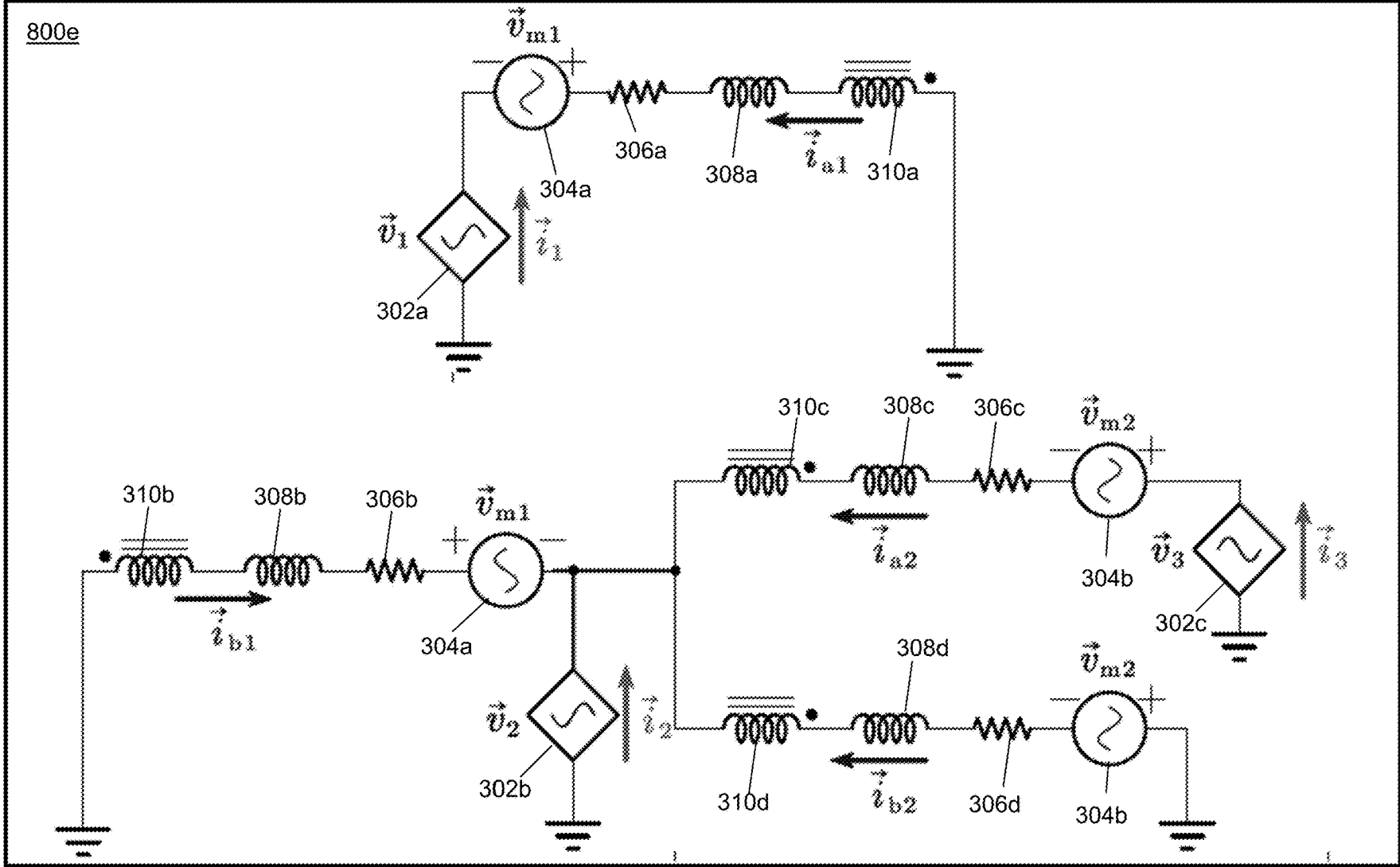

FIG. 8E

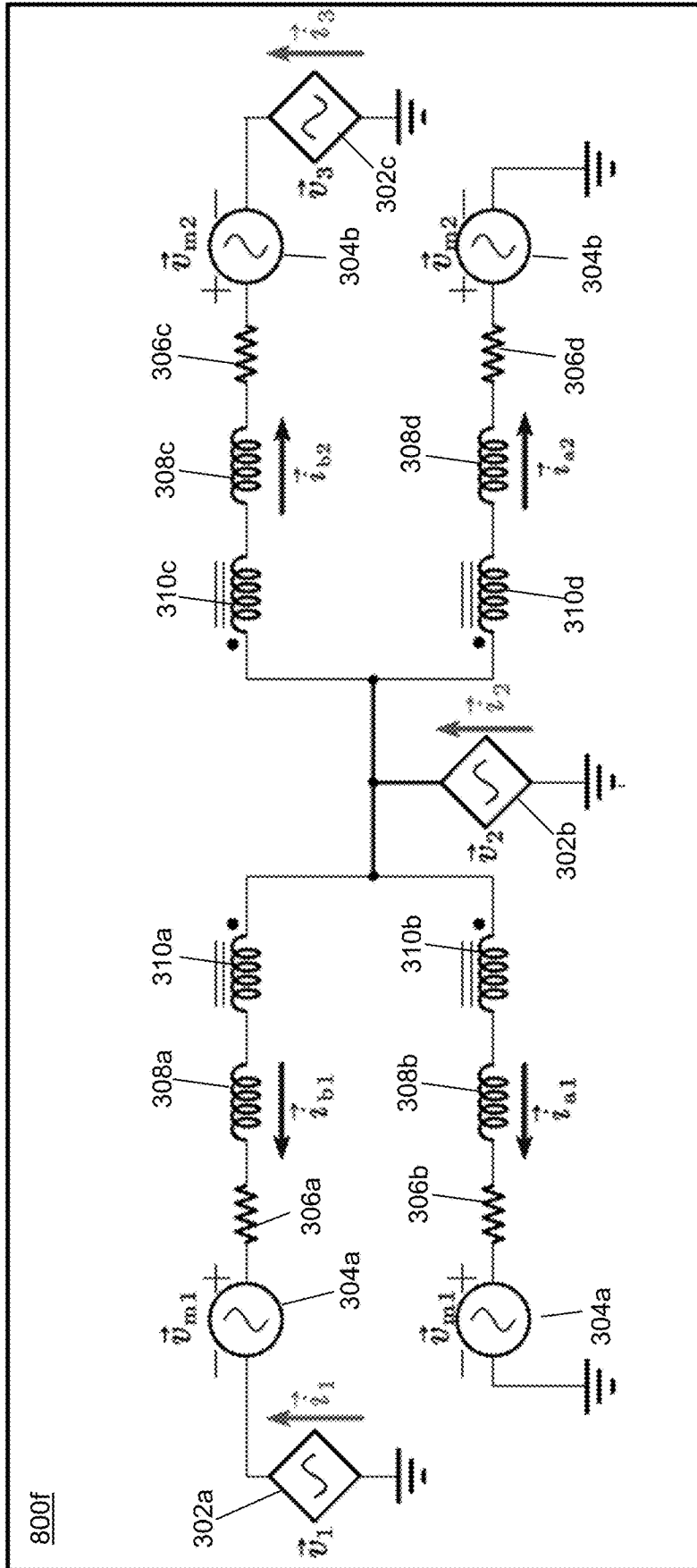

FIG. 8F

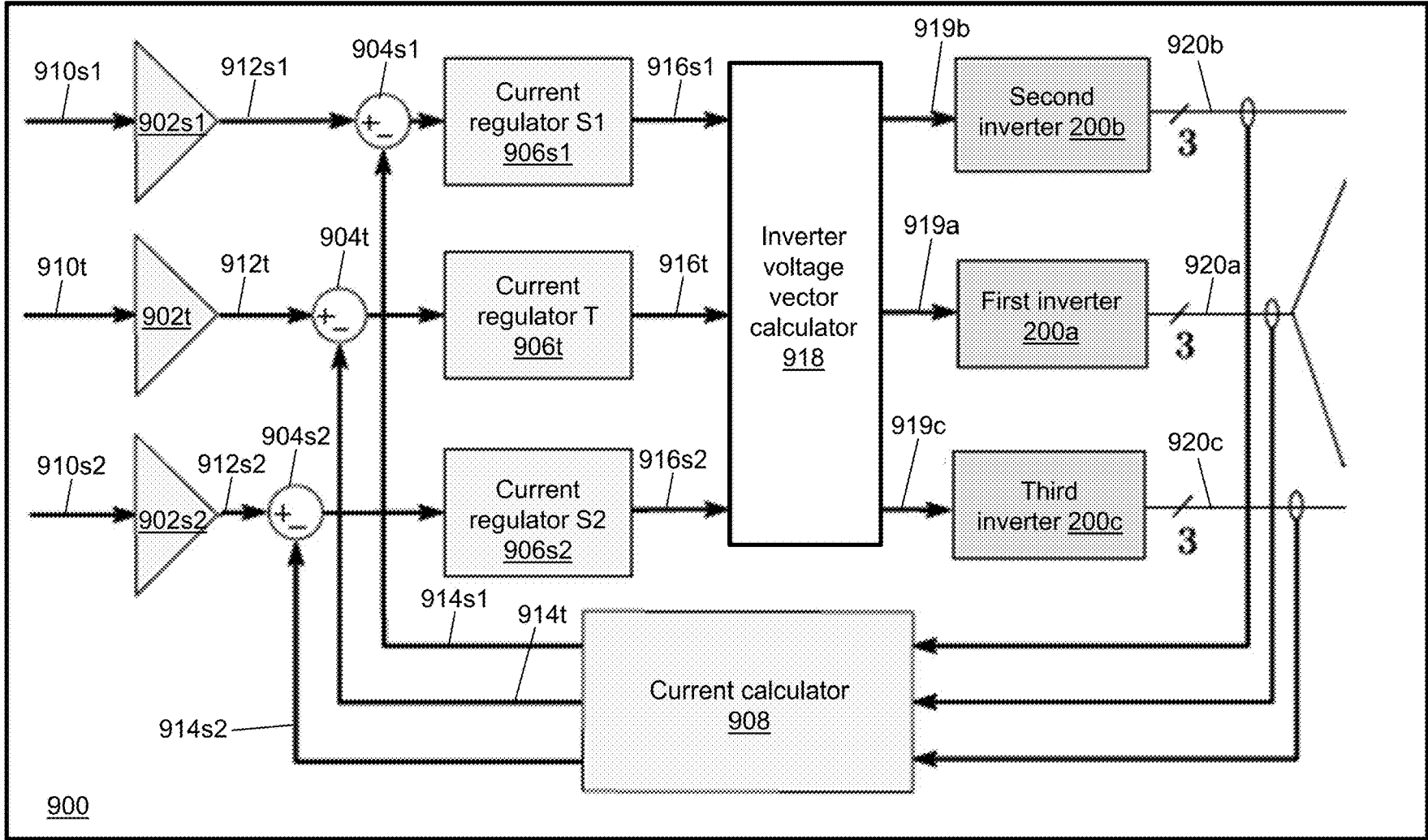

FIG. 9

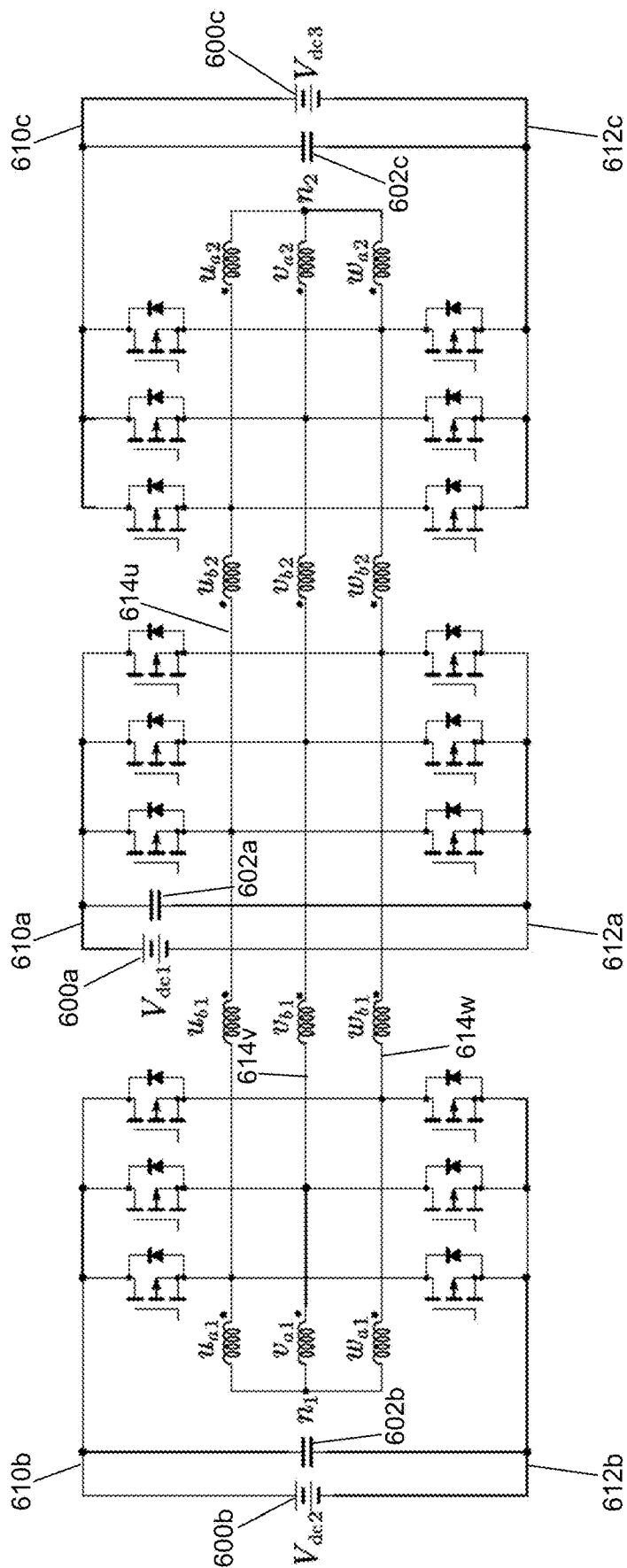

FIG. 10

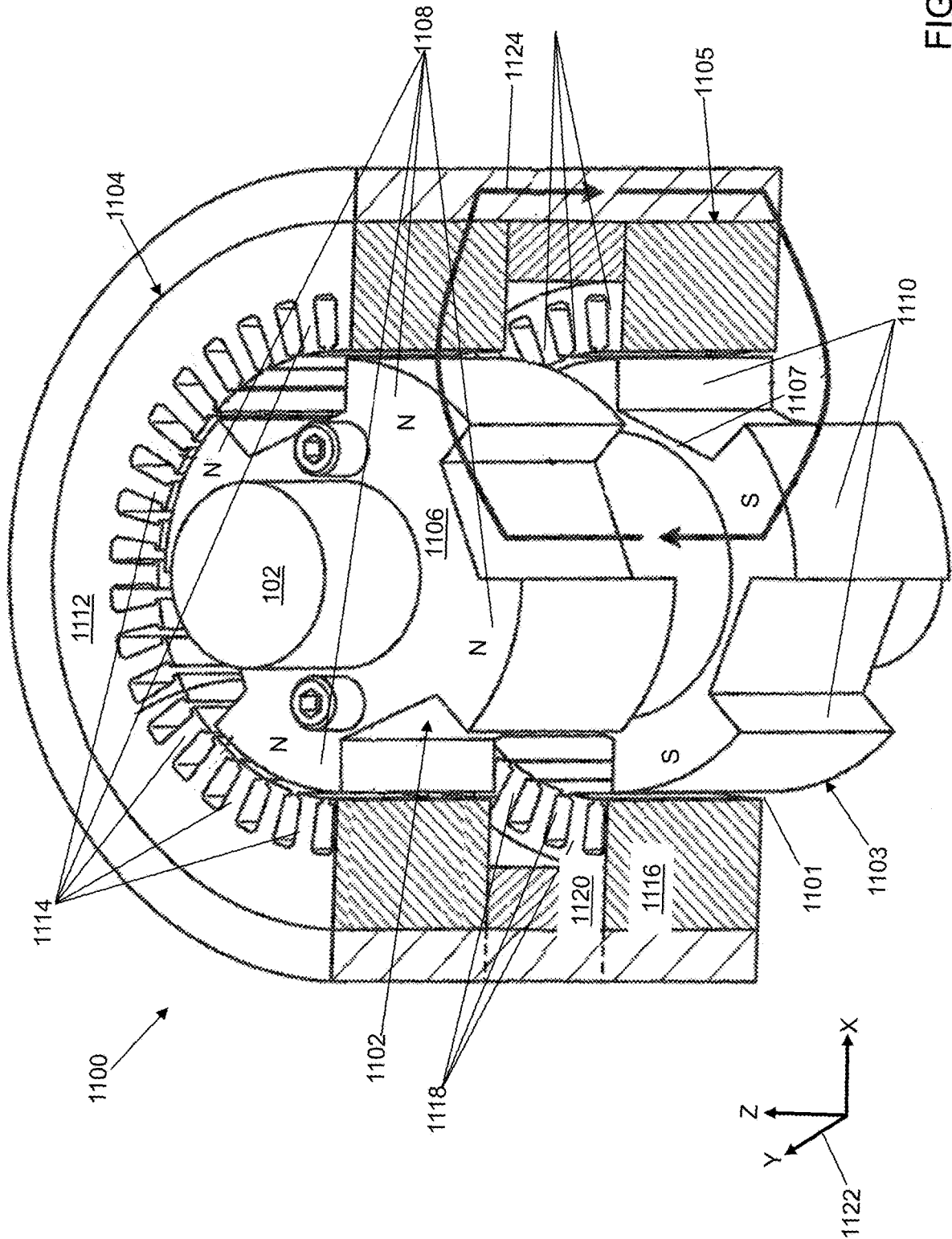

FIG. 11

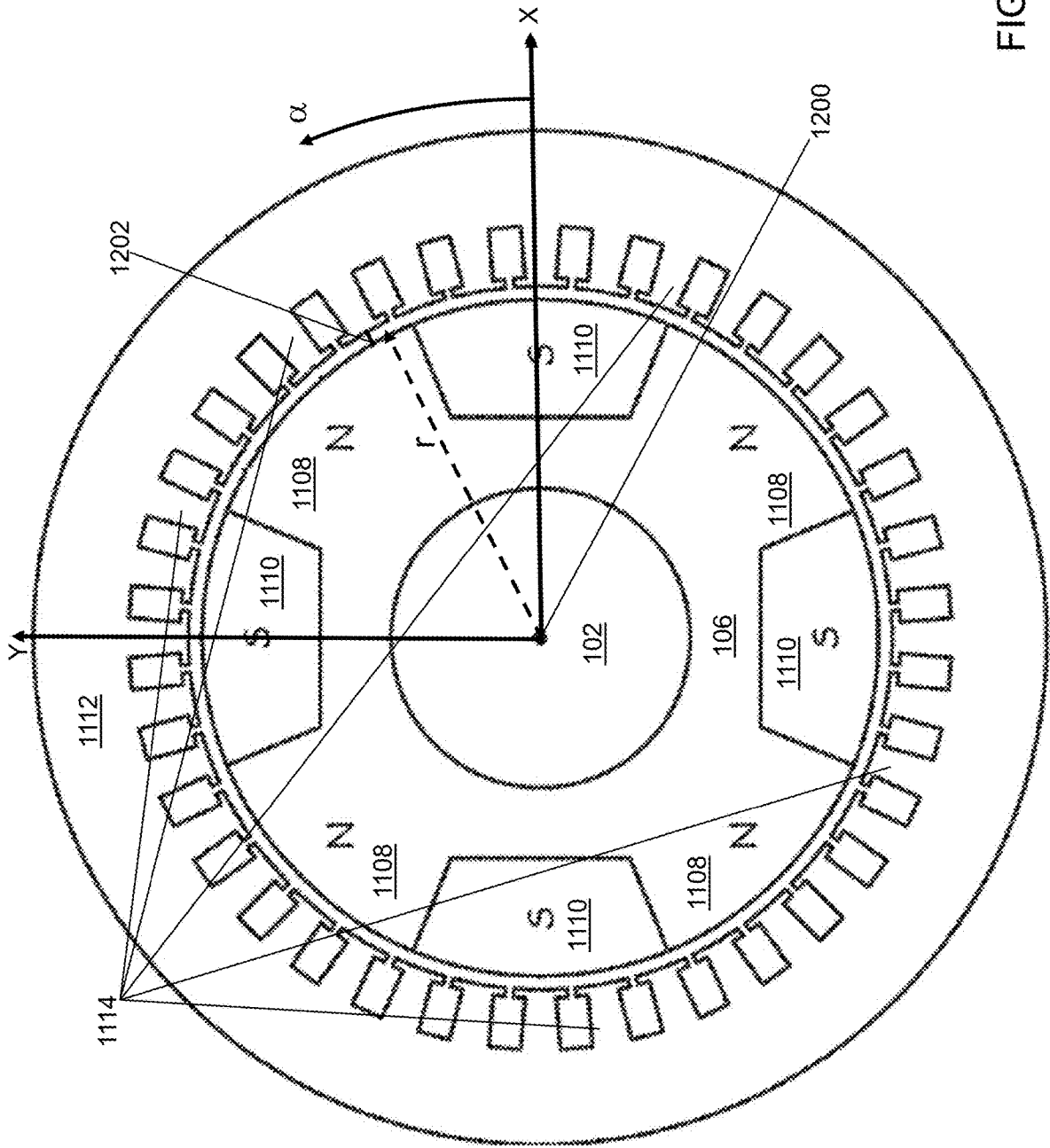

FIG. 12

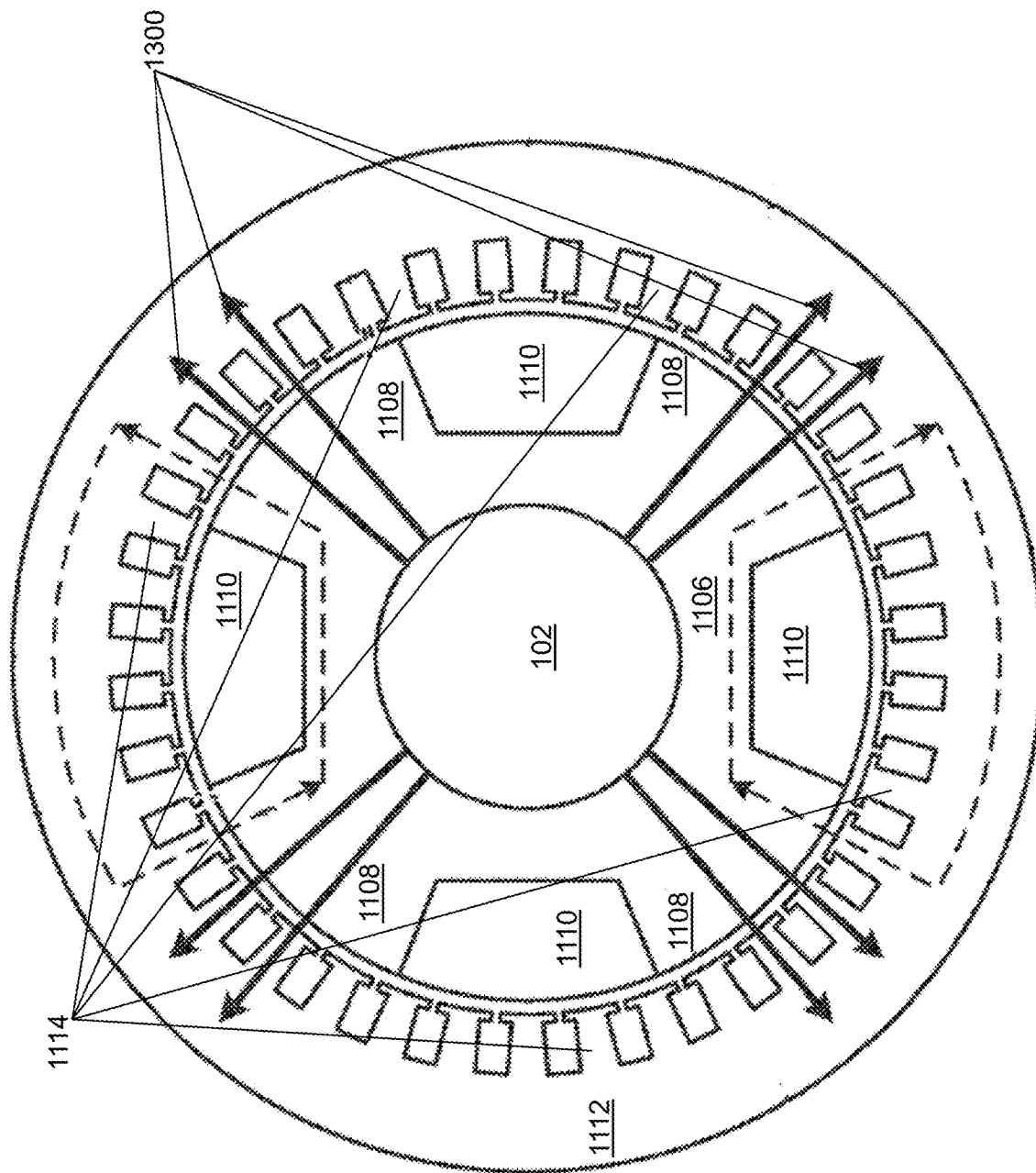

FIG. 13

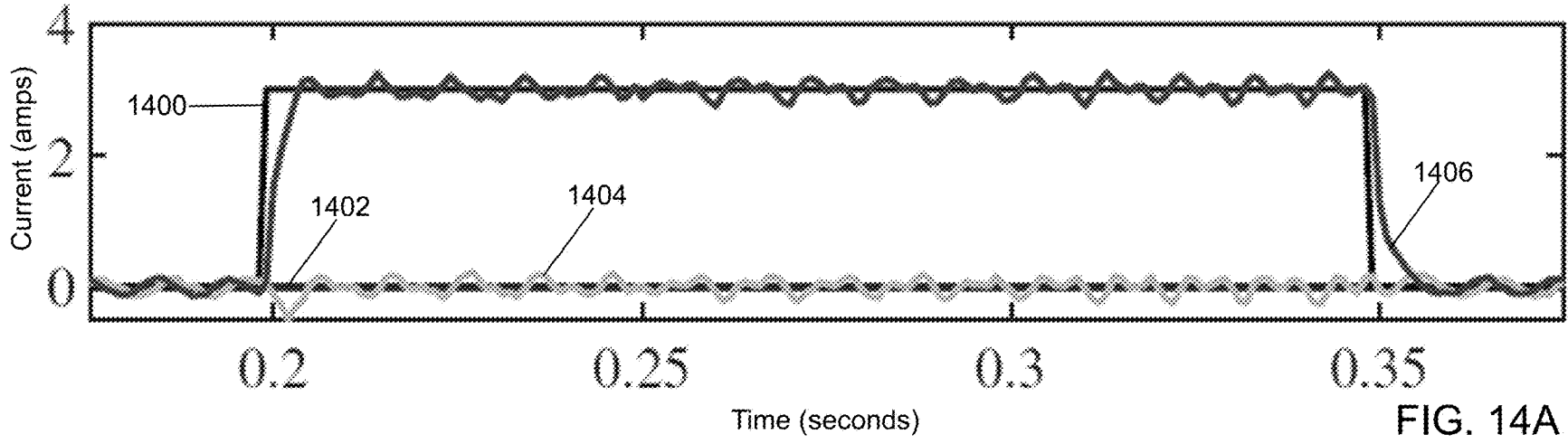

FIG. 14A

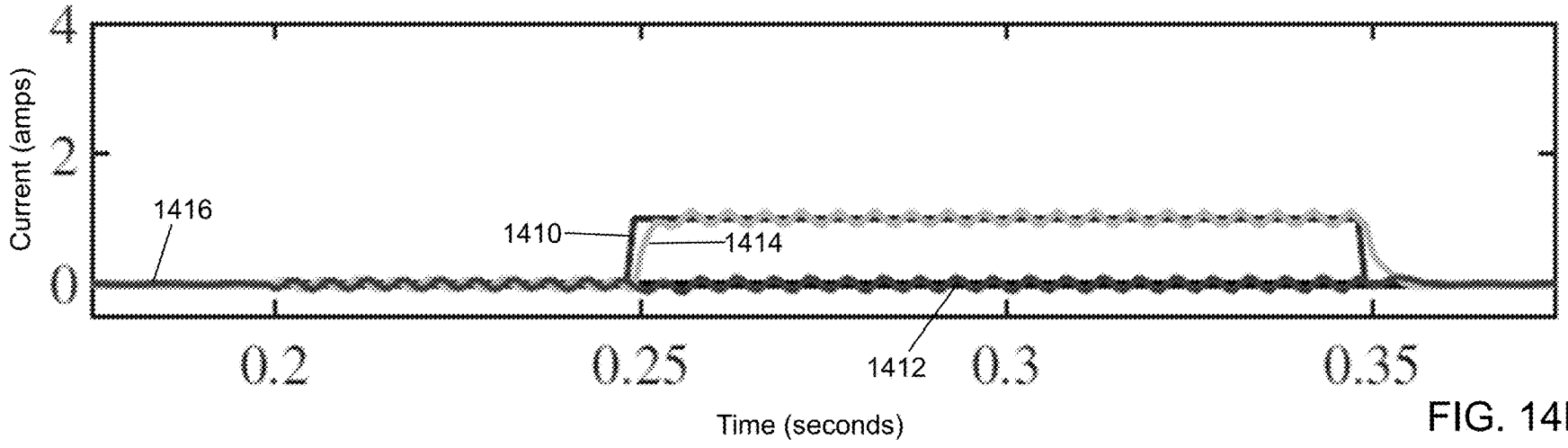

FIG. 14B

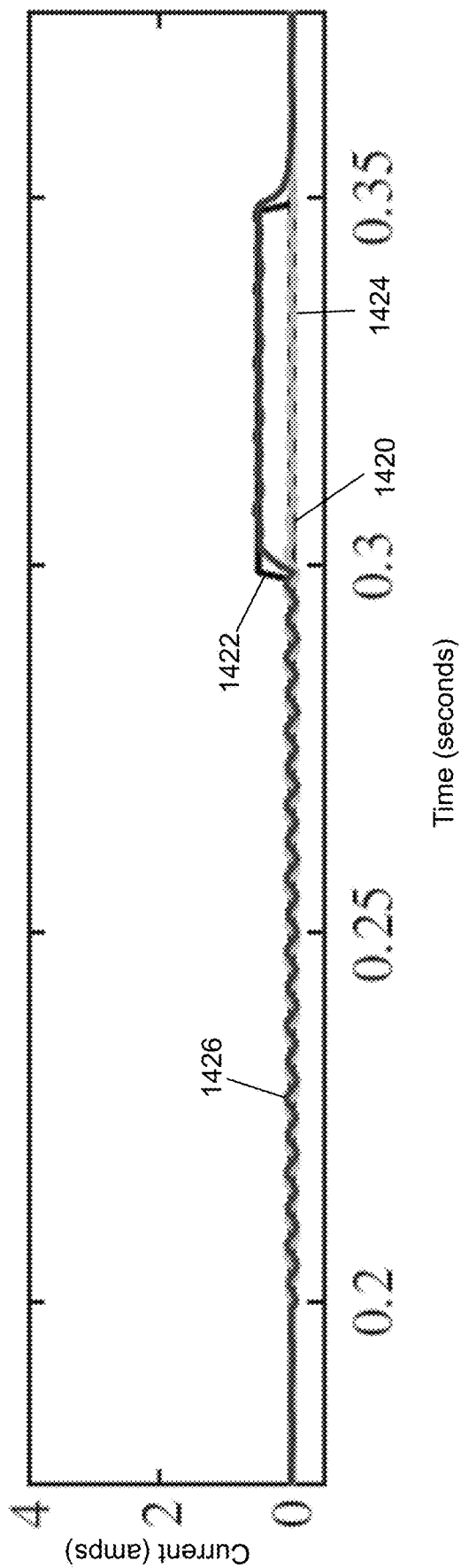

FIG. 14C

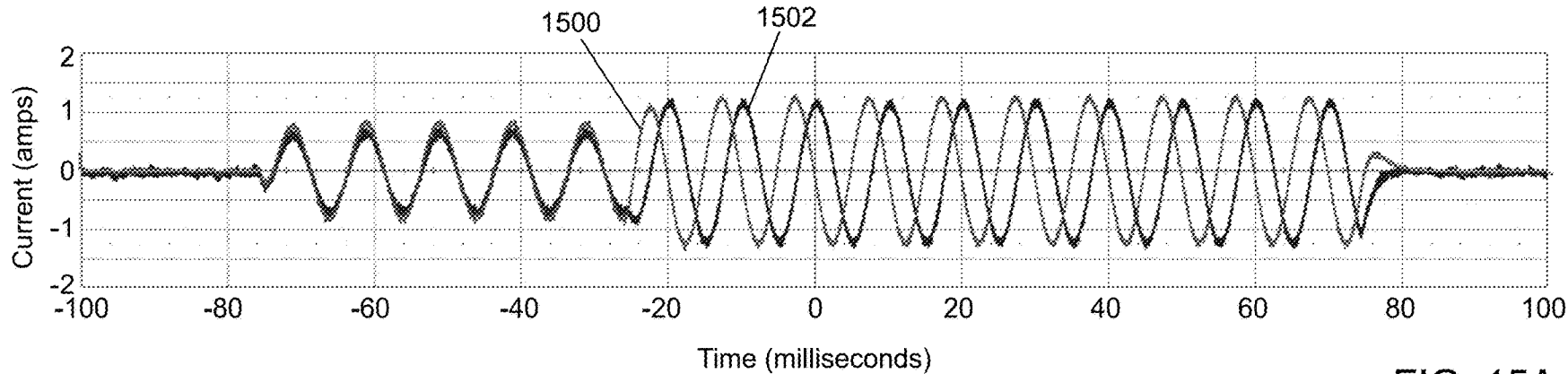

FIG. 15A

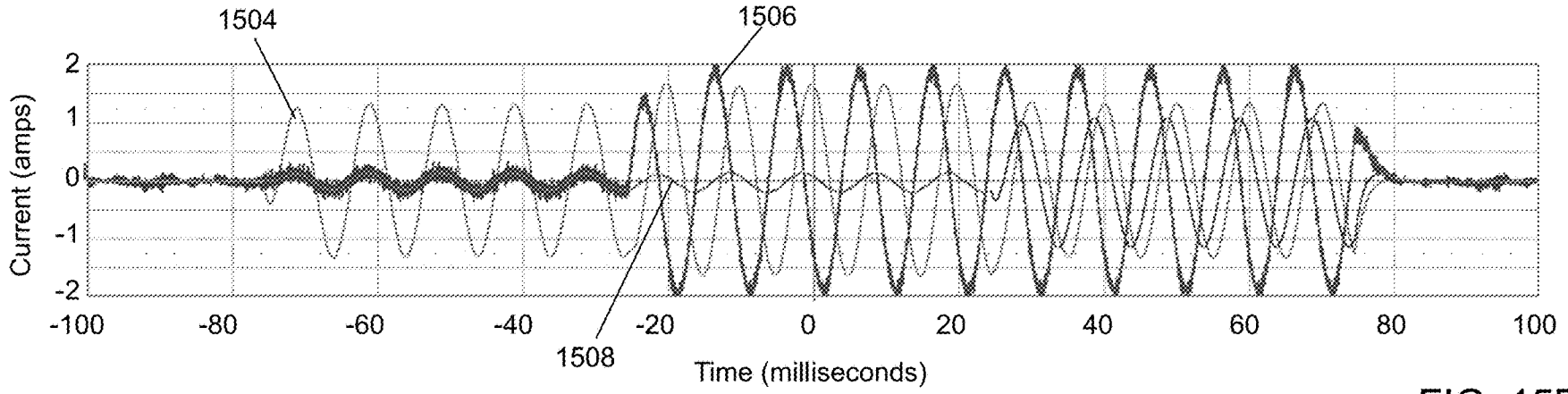

FIG. 15B

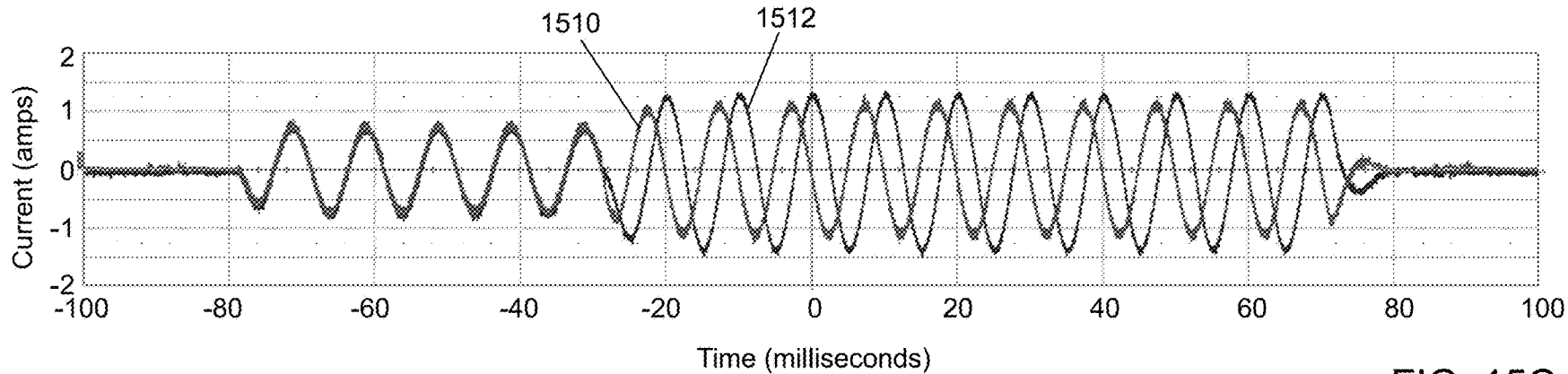

FIG. 15C

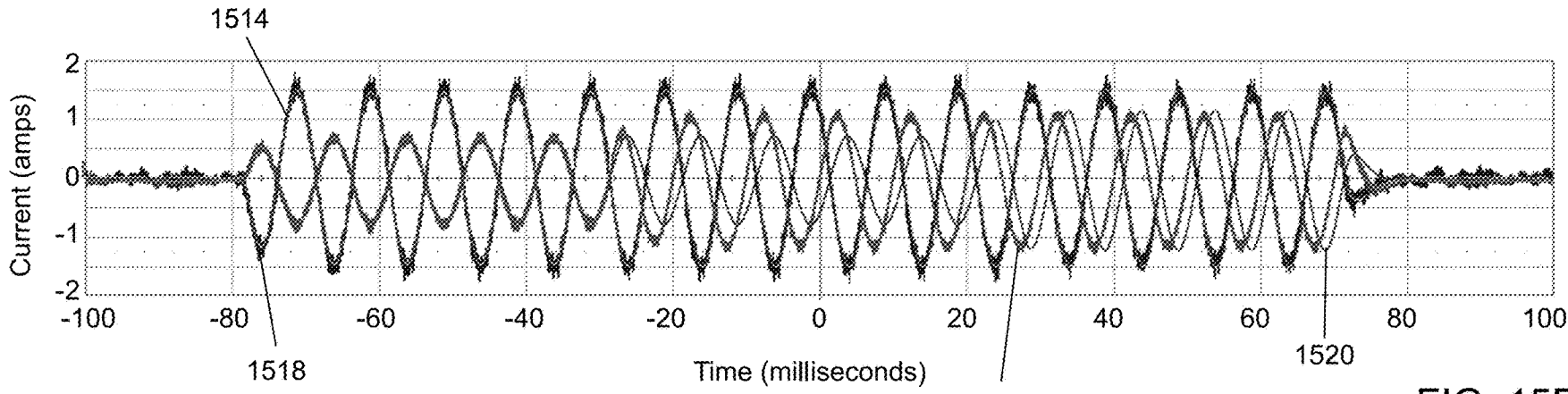

FIG. 15D

BEARINGLESS ELECTRICAL MACHINES WITH REDUCED NUMBER OF INVERTERS

BACKGROUND

[0001] Bearingless motors provide the functionality of a magnetic bearing and a motor in a single electric machine. Compared to systems that utilize a motor with separate magnetic bearings, bearingless technology results in a more integrated system that requires less raw material and can be designed for higher speeds due to shorter shaft lengths. Applications range from low speed, hygienic mixing devices, pumps, and artificial hearts to high and ultra-high speed machines for flywheels, spindle tools, and turbomachinery, etc. Bearingless motors have been widely developed as both asynchronous and synchronous motors, such as permanent magnet, synchronous reluctance, induction, consequent pole, and ac homopolar motors.

[0002] Using combined windings, the same stator coils are used for both torque and force creation. The combined winding allows the bearingless drive to dynamically allocate the stator's ampere turns to create force or torque based on real-time operating requirements. This facilitates better stator current utilization. Of the various combined winding approaches, multiphase (MP) and dual purpose no voltage (DPNV) windings are recognized as high performance solutions because of their ability to independently actuate torque, field weakening, and suspension force. Unfortunately, combined windings have been shown to increase the complexity and therefore, the cost of the power electronics required for bearingless motors.

SUMMARY

[0003] In an example embodiment, a bearingless electrical machine system is provided that includes, but is not limited to, a shaft, a first rotor mounted to rotate with the shaft, a first stator, a second rotor mounted to rotate with the shaft, a second stator, a first, first-phase coil and a second, first-phase coil of a first stator winding wound about the first stator, a first, second-phase coil and a second, second-phase coil of a second stator winding wound about the first stator, a first, third-phase coil and a second, third-phase coil of a third stator winding wound about the first stator, a first, first-phase coil and a second, first-phase coil of a fourth stator winding wound about the second stator, a first, second-phase coil and a second, second-phase coil of a fifth stator winding wound about the second stator, a first, third-phase coil and a second, third-phase coil of a sixth stator winding wound about the second stator, and an inverter drive system. The first stator is mounted on a side of the first rotor separated by a first air gap between a surface of the first rotor and a surface of the first stator. The second stator is mounted on a side of the second rotor separated by a second air gap between a surface of the second rotor and a surface of the second stator. The first stator winding is configured to provide a torque and a suspension force relative to the shaft when current is provided to the first stator winding. The second stator winding is configured to provide the torque and the suspension force relative to the shaft when current is provided to the second stator winding. The third stator winding is configured to provide the torque and the suspension force relative to the shaft when current is provided to the third stator winding. The fourth stator winding is configured to provide the torque and the suspension force relative to the shaft when current

is provided to the fourth stator winding. The fifth stator winding is configured to provide the torque and the suspension force relative to the shaft when current is provided to the fifth stator winding. The sixth stator winding is configured to provide the torque and the suspension force relative to the shaft when current is provided to the sixth stator winding. The inverter drive system consists of only a first inverter, a second inverter, and a third inverter. Each inverter of the inverter drive system comprises a first connection for a first-phase, a second connection for a second-phase, and a third connection for a third-phase. Each first-phase coil is connected to the first connection of the first inverter, the second inverter, or the third inverter. Each second-phase coil is connected to the second connection of the first inverter, the second inverter, or the third inverter. Each third-phase coil is connected to the third connection of the first inverter, the second inverter, or the third inverter.

[0004] Other principal features of the disclosed subject matter will become apparent to those skilled in the art upon review of the drawings described below, the detailed description, and the appended claims.

BRIEF DESCRIPTION OF THE DRAWINGS

[0005] Illustrative embodiments of the disclosed subject matter will hereafter be described referring to the accompanying drawings, wherein like numerals denote like elements.

[0006] FIG. 1 depicts a diagram of a twin bearingless machine system in accordance with an illustrative embodiment.

[0007] FIG. 2A depicts a multiphase (MP) winding configuration in accordance with an illustrative embodiment.

[0008] FIG. 2B depicts a parallel, dual purpose no voltage (DPNV) combined winding configuration in accordance with an illustrative embodiment.

[0009] FIG. 3 depicts a space-vector diagram of the parallel DPNV combined winding configuration of FIG. 2B in accordance with an illustrative embodiment.

[0010] FIGS. 4A-4J depict stator winding connections with three inverters for the twin bearingless machine system of FIG. 1 in accordance with an illustrative embodiment.

[0011] FIG. 5 depicts a space-vector diagram for the winding configuration of FIG. 4A in accordance with an illustrative embodiment.

[0012] FIG. 6A depicts a circuit diagram for the winding configuration of FIG. 4A in accordance with an illustrative embodiment.

[0013] FIG. 6B depicts a zoomed view of the circuit diagram FIG. 6A showing a first inverter and a second inverter in accordance with an illustrative embodiment.

[0014] FIG. 6C depicts a zoomed view of the circuit diagram FIG. 6A showing the first inverter and a third inverter in accordance with an illustrative embodiment.

[0015] FIG. 6D depicts a circuit diagram for the winding configuration of FIG. 4I in accordance with an illustrative embodiment.

[0016] FIGS. 7A-7G depict alternative drive structures for the twin bearingless machine system of FIG. 1 in accordance with an illustrative embodiment.

[0017] FIGS. 8A-8F depict space-vector diagrams for the stator winding configurations of FIG. 4C-4H, respectively, in accordance with an illustrative embodiment.

[0018] FIG. 9 depicts a block diagram of a control architecture for a drive with three inverters for the twin bearingless machine system of FIG. 1 in accordance with an illustrative embodiment.

[0019] FIG. 10 depicts a circuit diagram for the winding configuration of FIG. 4A with three isolated direct current voltage sources in accordance with an illustrative embodiment.

[0020] FIG. 11 depicts a front perspective view of a radial flux machine in accordance with an illustrative embodiment.

[0021] FIG. 12 depicts a top view of the radial flux machine of FIG. 11 in accordance with an illustrative embodiment.

[0022] FIG. 13 depicts the top view of the radial flux machine of FIG. 12 showing force fields in accordance with an illustrative embodiment.

[0023] FIG. 14A shows torque currents generated using the winding configuration of FIG. 4A in accordance with an illustrative embodiment.

[0024] FIG. 14B shows first suspension force currents generated using the winding configuration of FIG. 4A in accordance with an illustrative embodiment.

[0025] FIG. 14C shows second suspension force currents generated using the winding configuration of FIG. 4A in accordance with an illustrative embodiment.

[0026] FIG. 15A shows phase currents generated using the winding configuration of FIG. 4A in accordance with an illustrative embodiment.

[0027] FIG. 15B shows output inverter currents generated using the winding configuration of FIG. 4A in accordance with an illustrative embodiment.

[0028] FIG. 15C shows phase currents generated using a parallel DPNV combined winding configuration with four inverters in accordance with an illustrative embodiment.

[0029] FIG. 15D shows output inverter currents generated using the parallel DPNV combined winding configuration with four inverters in accordance with an illustrative embodiment.

DETAILED DESCRIPTION

[0030] Referring to FIG. 1, a twin bearingless machine system 100 is shown in accordance with an illustrative embodiment. By relying on a first bearingless machine 104a and a second bearingless machine 104b for tilting and radial force control, twin bearingless machine system 100 includes only a single axial magnetic bearing 106. An inverter drive system 108 includes three inverters to control first bearingless machine 104a and second bearingless machine 104b instead of the typical four inverters resulting in a significant decrease in cost. First bearingless machine 104a, second bearingless machine 104b, and axial magnetic bearing 106 are mounted to a shaft 102 for simultaneous rotation with shaft 102. When twin bearingless machine system 100 is operated as a generator, shaft 102 is rotated under control of an external force to generate electricity. When twin bearingless machine system 100 is operated as a motor, shaft 102 is rotated under control of inverter drive system 108.

[0031] Controller 110 determines and sends control signals to inverter drive system 108. Controller 110 may include an input/output (I/O) interface 112, a non-transitory computer-readable medium 114, a processor 116, and a control application 118. Fewer, different, and/or additional components may be incorporated into controller 110.

[0032] I/O interface 112 provides an interface for receiving and/or for outputting information from/to the user or another device for entry into controller 110 or output from controller 110 as understood by those skilled in the art. I/O interface 112 may interface with various I/O technologies including, but not limited to, a keyboard, a mouse, a display, a track ball, a keypad, one or more buttons, an Ethernet port, a Bluetooth antenna, etc. to allow the user or another device to provide or receive information to/from controller 110. I/O interface 112 may receive and/or transmit data or other electrical signals between devices using various protocols, transmission technologies, and media as understood by those skilled in the art. I/O interface 112 may support communication using various transmission media that may be wired and/or wireless. Controller 110 may have one or more I/O interfaces that use the same or a different I/O interface technology.

[0033] Computer-readable medium 114 is an electronic holding place or storage for information so the information can be accessed by processor 116 as understood by those skilled in the art. Computer-readable medium 114 can include, but is not limited to, any type of random access memory (RAM), any type of read only memory (ROM), any type of flash memory, etc. such as magnetic storage devices (e.g., hard disk, floppy disk, magnetic strips, . . .), optical disks (e.g., compact disc (CD), digital versatile disc (DVD), . . .), smart cards, flash memory devices, etc. Controller 110 may have one or more computer-readable media that use the same or a different memory media technology. For example, computer-readable medium 114 may include different types of computer-readable media that may be organized hierarchically to provide efficient access to the data stored therein as understood by a person of skill in the art.

[0034] Processor 116 executes instructions as understood by those skilled in the art. The instructions may be carried out by a special purpose computer, logic circuits, or hardware circuits. Processor 116 may be implemented in hardware and/or firmware. Processor 116 executes an instruction, meaning it performs/controls the operations called for by that instruction. The term “execution” is the process of running an application or the carrying out of the operation called for by an instruction. The instructions may be written using one or more programming language, scripting language, assembly language, etc. Processor 116 operably couples with I/O interface 112 to receive and to send information and with computer-readable medium 114 to process information. Processor 116 may retrieve a set of instructions from a permanent memory device and copy the instructions in an executable form to a temporary memory device that is generally some form of RAM. Controller 110 may include a plurality of processors that use the same or a different processing technology.

[0035] Control application 118 performs operations associated with receiving sensor signals such as current sensor data and computing gate signals for input to inverter drive system 108. The operations may be implemented using hardware, firmware, software, or any combination of these methods.

[0036] Referring to the example embodiment of FIG. 1, control application 118 is implemented in software (comprised of computer-readable and/or computer-executable instructions) stored in computer-readable medium 114 and accessible by processor 116 for execution of the instructions that embody the operations of control application 118.

Control application **118** may be written using one or more programming languages, assembly languages, scripting languages, etc. Control application **118** may be integrated with other analytic tools.

[0037] Twin bearingless machine system **100** may include first bearingless machine **104a** and second bearingless machine **104b** that each use a multiphase (MP) and/or a parallel DPNV combined winding to independently control torque, field weakening, and force with a minimum number of drive phases. While the literature typically treats combined winding as two distinct windings, both the MP and parallel DPNV winding configurations actually use the same machine winding layout, albeit with different drive connections, and therefore are fundamentally the same winding technology.

[0038] For illustration, first bearingless machine **104a** and second bearingless machine **104b** may each be implemented as a bearingless machine as described in a paper titled *Design of an Ultra-High Speed Bearingless Motor for Significant Rated Power* by Ashad Farhan et al., IEEE Energy Conversion Congress and Exposition pages 246-253 (Oct. 11, 2020). For further illustration, first bearingless machine **104a** and second bearingless machine **104b** may each be implemented as a bearingless machine as described in a paper titled *Practical Implementation of Dual-Purpose No-Voltage Drives for Bearingless Motors* by Eric Severson et al., IEEE TRANSACTIONS ON INDUSTRY APPLICATIONS, VOL. 52, NO. 2, MARCH/APRIL 2016. For still further illustration, first bearingless machine **104a** and second bearingless machine **104b** may each be implemented as a bearingless machine as described in U.S. Patent Publication No. 2021/0184550 titled ROTOR WINDING WITH A NEUTRAL PLATE FOR A BEARINGLESS INDUCTION MACHINE and published Jun. 17, 2021.

[0039] Referring to FIG. 11, a front perspective view of a radial flux machine **1100** is shown in accordance with an illustrative embodiment. Referring to FIG. 12, a top view of radial flux machine **1100** is shown in accordance with an illustrative embodiment. Referring to FIG. 13, the top view of radial flux machine **1100** showing a radial force is shown in accordance with an illustrative embodiment. Radial flux machine **1100** can be implemented as any type of radial flux machine such as a permanent magnet (PM) machine, a synchronous reluctance machine, an induction machine, a consequent-pole machine, an alternating current (AC) homopolar machine, etc. In the illustrative embodiment of FIG. 11, radial flux machine **1100** is an AC homopolar bearingless motor.

[0040] In an illustrative embodiment, radial flux machine **1100** forms an AC homopolar machine that may include a top rotor **1102**, a bottom rotor **1103**, a top stator **1104**, a bottom stator **1105**, a field winding **1120**, and shaft **102**. Merely for illustration, first bearingless machine **104a** and second bearingless machine **104b** may be implemented as radial flux machine **1100**. Thus, twin bearingless machine system **100** may be a single radial flux machine **1100** that forms first bearingless machine **104a** and second bearingless machine **104b** because it includes top rotor **1102** mounted adjacent top stator **1104** and bottom rotor **1103** mounted adjacent bottom stator **1105** that form two bearingless machines.

[0041] Top rotor **1102** is positioned radially interior of top stator **1104** separated by a top air gap **1202** that varies circumferentially around top rotor **1102** based on a location

of poles of top rotor **1102**. Similarly, bottom rotor **1103** is positioned radially interior of bottom stator **1105** separated by a bottom air gap **1101**. In the illustrative embodiment of FIG. 11, top rotor **1102** and bottom rotor **1103** are mounted interior of top stator **1104** and bottom stator **1105**, respectively, though top stator **1104** and bottom stator **1105** could instead be mounted interior of top rotor **1102** and bottom rotor **1103** in an alternative embodiment. Top stator **1104**, bottom stator **1105**, and shaft **102** have generally circular cross sections as shown with reference to FIG. 11. In alternative embodiments, radial flux machine **1100** can include a fewer or a greater number of stators and rotors depending on the machine type.

[0042] Top rotor **1102** and bottom rotor **1103** are mounted to shaft **102** for rotation with shaft **102**. When radial flux machine **1100** is operating as a motor, electrical energy provided to top stator **1104** and to bottom stator **1105** rotates top rotor **1102** and bottom rotor **1103**, and thereby shaft **102**. When radial flux machine **1100** is operating as a generator, shaft **102** is rotated to generate electrical energy from stator windings of top stator **1104** and bottom stator **1105**.

[0043] Top stator **1104** and bottom stator **1105** may be formed of a ferromagnetic material such as iron, cobalt, nickel, etc. Top stator **1104** may include a top stator core **1112** and a top plurality of teeth **1114**. In the illustrative embodiment, the top plurality of teeth **1114** extend from top stator core **1112** towards a center **1200** of an interior of shaft **102**. Top stator slots are formed between successive pairs of the top plurality of teeth **1114**. In the illustrative embodiment, the top plurality of teeth **1114** of top stator **1104** includes 36 teeth that define 36 stator slots.

[0044] Bottom stator **1105** may include a bottom stator core **1116** and a bottom plurality of teeth **1118**. In the illustrative embodiment, the bottom plurality of teeth **1118** extend from bottom stator core **1116** towards center **1200** of the interior of shaft **102**. Bottom stator slots are formed between successive pairs of the bottom plurality of teeth **1118**. In the illustrative embodiment, the bottom plurality of teeth **1118** of bottom stator **1105** includes 36 teeth that define 36 stator slots.

[0045] As understood by a person of skill in the art, top stator **1104** and bottom stator **1105** may be formed of laminations mounted closely together and stacked in a z-direction indicated by a z-axis and cut to define a shape and a size of top stator core **1112** and the top plurality of teeth **1114** and of bottom stator core **1116** and the bottom plurality of teeth **1118**. An x-axis is perpendicular to a y-axis, and both the x-axis and the y-axis are perpendicular to the z-axis to form a right-handed coordinate reference frame denoted x-y-z frame **1122**. The x-y plane defines a cross section of radial flux machine **1100** and the z-axis defines a height of radial flux machine **1100**.

[0046] The top plurality of teeth **1114** and the bottom plurality of teeth **1118** extend from top stator core **1112** and from bottom stator core **1116** at equal angular intervals and have a common arc length dimension. Each tooth of the top plurality of teeth **1114** and of the bottom plurality of teeth **1118** may generally form a "T" shape though other shapes may be used in alternative embodiments.

[0047] Top rotor **1102** may be formed of a ferromagnetic material such as iron, cobalt, nickel, etc. Top rotor **1102** may include a top rotor core **1106** and a plurality of top rotor pole pieces **1108** mounted exterior of top rotor core **1106**. In the illustrative embodiment, the top rotor pole pieces **1108**

extend outward from top rotor core **1106** toward the top plurality of teeth **1114** of top stator **1104**. As understood by a person of skill in the art, top rotor **1102** may be formed of laminations mounted closely together and stacked in the z-direction.

[0048] Bottom rotor **1103** may be formed of a ferromagnetic material such as iron, cobalt, nickel, etc. Bottom rotor **1103** may include a bottom rotor core **1107** and a plurality of bottom rotor pole pieces **1110** mounted exterior of bottom rotor core **1107**. In the illustrative embodiment, the bottom rotor pole pieces **1110** extend outward from bottom rotor core **1107** toward the bottom plurality of teeth **1118** of bottom stator **1105**. As understood by a person of skill in the art, bottom rotor **1103** may be formed of laminations mounted closely together and stacked in the z-direction.

[0049] In the illustrative embodiment, the plurality of top rotor pole pieces **1108** and the plurality of bottom rotor pole pieces **1110** have a generally polygonal shape with a curved exterior surface adjacent top stator **1104** and bottom stator **1105**, respectively, though the plurality of top rotor pole pieces **1108** and the plurality of bottom rotor pole pieces **1110** may have various shapes based on a type of electrical machine of radial flux machine as understood by a person of skill in the art. In the illustrative embodiment, the plurality of top rotor pole pieces **1108** and the plurality of bottom rotor pole pieces **1110** each include four pole pieces though a fewer or a greater number of pole pieces may be formed to extend from top rotor core **1106** and from bottom rotor core **1107**, respectively, in alternative embodiments. The plurality of top rotor pole pieces **1108** and the plurality of bottom rotor pole pieces **1110** include at least two pole pieces.

[0050] Field winding **1120**, or permanent magnets in alternative embodiments, creates a magnetization indicated by a north (N) and a south (S) pole indicator for top rotor **1102** and for bottom rotor **1103**. Field winding **1120**, or the permanent magnets, create a magnetomotive force resulting in flux that flows along a flux path **1124** shown at an instant in time as top rotor **1102** and bottom rotor **1103** rotate about the z-axis defined through center **200**.

[0051] Stator windings (not shown in FIGS. **1-3**) are wound around the top plurality of teeth **1114** and the bottom plurality of teeth **1118** and held within the top stator slots and the bottom stator slots, respectively. The stator windings carry a current between a set of connectors (not shown in FIGS. **1-3**) also called terminals. The stator windings are connected to three inverters in various configurations as discussed further below. One or more windings may be used for each phase. The stator windings are wound around the top plurality of teeth **1114** and the bottom plurality of teeth **1118** using various techniques to form a number of magnetic pole-pairs p between a set of connectors that carry one phase of a plurality of phases of electrical current depending on the winding technique as discussed further below. For example, radial flux machine **1100** may include stator windings with a stator winding for each phase. For three phases designated as u, v, w, a first stator winding may be associated with a u-phase, a second stator winding may be associated with a v-phase, and a third stator winding may be associated with a w-phase.

[0052] Top rotor **1102** and bottom rotor **1103** further may include rotor windings and/or permanent magnets in alternative embodiments. When rotated, top rotor **1102** and bottom rotor **1103** produce a rotating magnetic field.

Through an interaction between the magnetic field and currents flowing in the windings a torque is generated to rotate shaft **102** such that radial flux machine **1100** operates as a motor. Alternatively, shaft **102** is mechanically rotated, which generates currents flowing in the stator windings such that radial flux machine **1100** operates as a generator. DPNV windings use the same stator winding for both torque and suspension forces and are a type of combined winding.

[0053] The stator windings can be connected to create a suspension force in top air gap **1202** and bottom air gap **1101**, respectively. For example, a radial suspension force **1300** created by the stator windings is shown in accordance with an illustrative embodiment in FIG. **13**. Controller **110** controls a flow of current through each coil of the stator windings to rotate shaft **102** to generate a torque and to create a radial suspension force on shaft **102**.

[0054] Radial flux bearingless motors produce radial suspension forces by creating an unsymmetrical flux density in top air gap **1202** and/or bottom air gap **1101**. Non-bearingless machines have symmetry that cancels the radial forces. The forces can be calculated using the Maxwell stress tensor, which for the idealized case of radial fields that do not vary with the axial length (along the z-axis), can be written as

$$F_x = \frac{lr}{2\mu_0} \int_0^{2\pi} B_r(\alpha)^2 \cos \alpha \, d\alpha$$

$$F_y = \frac{lr}{2\mu_0} \int_0^{2\pi} B_r(\alpha)^2 \sin \alpha \, d\alpha$$

[0055] where l is an active axial length, r is the air gap radius, and B_r is a cumulative radial flux density in top air gap **1202** and/or bottom air gap **1101** at angular location α shown referring to FIG. **12**. To create a radial force, $B_r(\alpha)$ contains components that differ in harmonic index by one.

[0056] For conventional radial flux machine types, such as PM or induction motors, and assuming that harmonics are neglected, a radial air gap flux density can be defined using $B_r(\alpha) = \hat{B}_r \cos(-p\alpha + \phi_r)$, where p represents the number of pole-pairs of radial flux machine **1100**, and ϕ_r indicates an angular location of a torque producing magnetic field at an instant of time. The magnetic field is composed of a magnetizing field (for example, produced by the PM's or a rotor winding) and an armature reaction field. To transform this type of motor into a bearingless motor, a suspension coil with either $p_s = p+1$ or $p_s = p-1$ pole-pairs can be added, for example, to top stator **1104** and to bottom stator **1105** in the illustrative embodiment, to produce a radial flux density that differs in harmonic index by one $B_s(\alpha) = \hat{B}_s \cos(-(p\pm 1)\alpha + \phi_s)$, where ϕ_s indicates an angular location of a suspension force producing magnetic field at an instant of time and p_s is a number of suspension pole-pairs. Thus, $B_r(\alpha) = \hat{B}_r \cos(-p\alpha + \phi_r) + \hat{B}_s \cos(-(p\pm 1)\alpha + \phi_s)$, which includes a torque flux density portion and a suspension flux density portion.

[0057] The suspension flux density portion is produced by balanced sinusoidal suspension currents

$$i_u = \hat{i}_s \cos \phi_s$$

$$i_v = \hat{i}_s \cos \left(\phi_s - \frac{2\pi}{3} \right)$$

$$i'_y = \hat{I}_s \cos\left(\phi_s + \frac{2\pi}{3}\right), \quad \text{-continued}$$

[0058] These currents can be transformed into an equivalent two-phase system using the well-known direct-quadrature (DQ) transformation. If this is done with respect to the angle ϕ_T , the following constant expressions for the radial force result

$$F_x = k_i i_x$$

$$F_y = k_i i_y$$

where i_x and i_y are the two-phase DQ currents, respectively, from the DQ transformation and $k_f = f(\hat{B}_T, \text{geometry})$. Typically, a suspension controller specifies required values of F_x and F_y that are used to determine phase currents via an inverse DQ transformation. Noting that ϕ_T increases at a speed of an armature winding frequency, to produce a constant force, the suspension currents have the same frequency as the armature currents.

[0059] An AC homopolar bearingless motor and a consequent-pole bearingless motor can be viewed as having a constant radial air gap flux density component that does not vary with the angular position, $B_T(\alpha) = \hat{B}_T$. Radial forces are produced by adding a $p_s = 1$ pole-pair suspension coil to the stator winding, which produces a flux density given by $B_S(\alpha) = \hat{B}_S \cos(-\alpha + \phi_S)$ with the suspension currents as defined previously.

[0060] A DQ transformation with $\phi_T = 0$ can be used to transform the suspension currents of the AC homopolar bearingless motor and the consequent-pole bearingless motor into equivalent x-y currents to compute the force expressions as defined above. The same inverse DQ transformation is used to calculate the suspension phase currents again with $\phi_T = 0$. Since $\phi_T = 0$, to produce a constant force, the suspension currents are direct current (DC). Additionally, no information regarding the air gap flux density's location is needed for suspension force creation, which may be an advantage of the AC homopolar bearingless motor and the consequent-pole bearingless motor. For the consequent-pole and AC homopolar motors, this requires $p \geq 4$.

[0061] The stator winding is responsible for generating two airgap magneto-motive forces (MMF): a p pole-pair MMF for torque and a p_s pole-pair MMF for suspension forces. While conventional bearingless motors use separate windings for creating each MMF, the DPNV windings use a single winding for creating both MMFs. The defining features of a DPNV winding can be summarized as: 1) using the same winding to construct a p pole-pair torque MMF and a p_s pole-pair suspension MMF; and 2) having suspension terminals which connect to the same winding as the torque terminals, but with half of the windings direction reversed so that these terminals experience no motional-electromotive force (EMF).

[0062] By definition, bearingless machines produce torque and suspension force simultaneously. This is typically modeled as $\vec{T} = T_d + j\tau = \bar{K}_t \vec{i}_t$ and $\vec{F} = F_x + jF_y = \bar{K}_f \vec{i}_s$, where T_d and τ represent flux weakening and shaft torque, F_x and F_y are shaft forces in the x and y direction, \vec{i}_t and \vec{i}_s are space vector transformations of the stator torque and suspension winding currents, and \bar{K}_t and \bar{K}_f are complex factors that relate the current space vectors to the motor and suspension

quantities and are of the form $\bar{K}_t = k_t e^{-j\theta_t}$ and $\bar{K}_f = k_f e^{-j\theta_f}$, respectively. k_t and k_f are machine constants, and θ_t and θ_f are determined from the rotor's angle and depend on the bearingless machine type.

[0063] In typical control systems, an outer control loop determines reference values for \vec{T}^* and \vec{F}^* that are converted to reference current space vectors \vec{i}_t^* and \vec{i}_s^* by solving $\vec{T} = T_d + j\tau = \bar{K}_t \vec{i}_t$ and $\vec{F} = F_x + jF_y = \bar{K}_f \vec{i}_s$. The relationship between \vec{i}_t^* , \vec{i}_s^* , the drive inverter's phase currents, and the motor winding currents depends on the type of winding used and the drive's connections to the winding.

[0064] As already stated, electric machines produce torque when the stator winding creates an airgap field with the same number of pole pairs p as the magnetizing field of the machine and that a bearingless machine produces force when the stator winding creates a second airgap field with $p_s = p \pm 1$ pole-pairs. Referring to FIG. 2A, a multiphase (MP) winding configuration is shown in accordance with an illustrative embodiment. The MP winding configuration may include a first inverter **200a** and a second inverter **200b**. A first MP winding **202a** is shown for a first stator such as top stator **1104**, and a second MP winding **202b** is shown for a second stator such as bottom stator **1105**. First inverter **200a** is connected to first MP winding **202a**, and second inverter **200b** is connected to second MP winding **202b**. A negative terminal of a first u-phase winding u_a is connected to a u-phase leg or half-bridge of first inverter **200a** as understood by a person of skill in the art. A positive terminal of the first u-phase winding u_a is connected to a neutral connector n_1 . A first v-phase winding v_a and a first w-phase winding w_a are similarly connected between first inverter **200a** and neutral connector **206a**. A second u-phase winding u_b , a second v-phase winding v_b , and a second w-phase winding w_b are similarly connected between second inverter **200b** and a neutral connector n_2 .

[0065] For the six-phase winding of FIG. 2A to create the torque and suspension fields, each phase's winding function contains these harmonics. By neglecting all other harmonics, the winding function for phase k , which is shown next to each coil such as $k=4$ for coil u_a , takes the form

$$N_k(\alpha) = \hat{N}_p \cos\left(p\alpha - [k-1]p\frac{\pi}{3}\right) + \hat{N}_{p_s} \cos\left(p_s\alpha - [k-1]p_s\frac{\pi}{3}\right), \quad k = 1, \dots, 6$$

where \hat{N}_p and \hat{N}_{p_s} are the amplitude at harmonic p and p_s and α is the angular location in the airgap. The torque p and suspension p_s pole-pair fields can be independently controlled by regulating the winding phase currents as

$$i_k = \hat{I}_t \cos\left(\phi_t - [k-1]p\frac{\pi}{3}\right) + \hat{I}_s \cos\left(\phi_s - [k-1]p_s\frac{\pi}{3}\right), \quad k = 1, \dots, 6$$

where \hat{I}_t and ϕ_t determine the amplitude and the angular location, respectively, of the pole-pair machine field, and \hat{I}_s and ϕ_s determine the amplitude and the angular location, respectively, of the pole-pair suspension field.

[0066] The amplitude invariant generalized Clarke transform may be used to calculate independent current space vectors from these phase currents as

$$\vec{i}_t = \frac{1}{3} \sum_{k=1}^6 i_k e^{j p [k-1] \frac{\pi}{3}} = \hat{i}_t e^{j \phi_t}$$

$$\vec{i}_s = \frac{1}{3} \sum_{k=1}^6 i_k e^{j p_s [k-1] \frac{\pi}{3}} = \hat{i}_s e^{j \phi_s}$$

[0067] Standard torque and force calculation approaches (e.g., the Maxwell stress tensor or co-energy) can be used with the current space vectors to determine the force and torque model summarized $\vec{T} = T_d + j\tau = \bar{k}_t \vec{i}_t$ and $\vec{F} = F_x + jF_y = \bar{k}_f \vec{i}_s$. Each drive inverter phase is rated to carry the same maximum phase current of \hat{i}_t and withstand the same back-electromotive force (EMF).

[0068] Referring to FIG. 2B, a parallel DPNV winding configuration is shown in accordance with an illustrative embodiment. The parallel DPNV winding configuration may include first inverter 200a and second inverter 200b. A first DPNV winding 204 is shown for the first stator such as top stator 1104 or for the second stator such as bottom stator 1105. First inverter 200a and second inverter 200b are connected to first DPNV winding 204. The negative terminal of the first u-phase winding u_a is connected to a u-phase half-bridge of first inverter 200a, and the positive terminal of the first u-phase winding u_a is connected to a u-phase half-bridge of second inverter 200b. The positive terminal of the first u-phase winding u_a is also connected to the positive terminal of the second u-phase winding u_b . The negative terminal of the second u-phase winding u_b is connected to a neutral connector n. The first v-phase winding v_a , the second v-phase winding v_b , the first w-phase winding w_a , and the second w-phase winding w_b are similarly connected between first inverter 200a, second inverter 200b, and the neutral connector n.

[0069] Connecting the drive in this manner changes the current and voltage requirements of each drive inverter phase as discussed in U.S. Pat. No. 10,879,829 that issued Dec. 29, 2020 and is titled BEARINGLESS ELECTRICAL MACHINE WITH FLOATING CAPACITOR. The parallel DPNV winding can be described as a three-phase winding, where each phase is divided into two coil groups (or subphases) a and b. For $p_s=2$ and $p=1$, the equivalency between the MP and parallel configuration may be based on a correspondence between the values of k shown in FIG. 2A and the coil group labels of $u_a, u_b, v_a, v_b, w_a, w_b$ shown in FIG. 2B with dots denoting a phase connection direction between negative terminals and positive terminals where the dot indicates the positive terminal. Other pole combinations may have a different correspondence between MP and DPNV windings. A conventional (three-phase) Clarke transform can be used to construct current space vectors for the current in each of the coil groups as

$$\vec{i}_x = \frac{2}{3} \left(i_{u_x} + i_{v_x} e^{j \frac{2\pi}{3}} + i_{w_x} e^{j \frac{4\pi}{3}} \right)$$

where x is either a or b and current is defined as positive entering the dotted terminal of each coil group. The torque and suspension current space vectors can be calculated in terms of \vec{i}_a and \vec{i}_b . The resulting space vectors can be related back to the coil group currents using

$$\vec{i}_t = \vec{i}_a + \vec{i}_b = 2\hat{i}_t e^{j \phi_t} \text{ and } \vec{i}_s = 0.5(\vec{i}_b - \vec{i}_a) = \hat{i}_s e^{j \phi_s}.$$

[0070] These expressions can be inverted to find the coil group currents in terms of \vec{i}_t and \vec{i}_s as $\vec{i}_a = 0.5(\vec{i}_t - \vec{i}_s)$ and $\vec{i}_b = 0.5(\vec{i}_t + \vec{i}_s)$. The drive inverter terminal currents can be solved as $\vec{i}_1 = \vec{i}_s - 0.5\vec{i}_t$ and $\vec{i}_2 = \vec{i}_t$. A behavior of this drive configuration can be summarized with a space-vector equivalent circuit or a first space-vector diagram 300, shown referring to FIG. 3. First space-vector diagram 300 indicates a first voltage source 302a, a first back EMF 304a, a first resistor 306a, a first inductor 308a, and a first mutual inductance 310a, a second voltage source 302b, a second back EMF 304b, a second resistor 306b, a second inductor 308b, and a second mutual inductance 310b of DPNV winding 204 for each phase. Currents $\vec{i}_a, \vec{i}_b, \vec{i}_1$, and \vec{i}_2 are also indicated. \vec{i}_1 and \vec{i}_2 indicate the currents from first inverter 200a and second inverter 200b, respectively. \vec{i}_a, \vec{i}_b indicate the currents through the first set of phase windings, u_a, v_a, w_a , and the second set of phase windings, u_b, v_b, w_b , respectively. First mutual inductance 310a and second mutual inductance 310b form a mutual inductance between the first set of phase windings, u_a, v_a, w_a , and the second set of phase windings, u_b, v_b, w_b . The dotted inductors represent a polarity of mutual inductance that corresponds to the dotted terminals of FIG. 2B.

[0071] By controlling first inverter 200a and second inverter 200b using $\vec{i}_1 = \vec{i}_s - 0.5\vec{i}_t$ and $\vec{i}_2 = \vec{i}_t$, the stator winding's phase currents become

$$i_k = \hat{i}_t \cos\left(\phi_t - [k-1]p\frac{\pi}{3}\right) + \hat{i}_s \cos\left(\phi_s - [k-1]p_s\frac{\pi}{3}\right), k = 1, \dots, 6,$$

meaning that both the MP and parallel DPNV connection approaches result in identical stator currents. However, the drive inverter's have quite different requirements for the parallel DPNV winding, with first inverter 200a having a phase current rating of $\vec{i}_t + \vec{i}_s$ and experiencing no back-EMF, while second inverter 200b has a phase current rating of $2\vec{i}_t$ and does experience the motor's back-EMF, first back EMF 304a and first back EMF 304b.

[0072] A natural extension of the drives to twin bearingless machine system 100 is to have an independent drive for each of the two stators resulting in four inverters. In this case, $\vec{T} = T_d + j\tau = \bar{k}_t \vec{i}_t$ and $\vec{F} = F_x + jF_y = \bar{k}_f \vec{i}_s$ is used for each of first bearingless machine 104a and second bearingless machine 104b, where each machine may be responsible for half of the total shaft torque on shaft 102. Taking this approach has the disadvantage of doubling the amount of power electronics required as compared to a single bearingless electric machine due to the pair of inverters required for each bearingless machine, which increases the cost and volume of the entire machine system.

[0073] When two drives are used to actuate first bearingless machine 104a and second bearingless machine 104b, the drive electronics are able to control more degrees of freedom than are required. That is, each drive solves $\vec{T} = T_d + j\tau = \bar{k}_t \vec{i}_t$ and $\vec{F} = F_x + jF_y = \bar{k}_f \vec{i}_s$ to actuate torque and force in the airgap of each machine; however, in a typical application, the user is only interested in actuating the total

shaft torque \vec{T} that may be split between first bearingless machine **104a** and second bearingless machine **104b**. As a result, the typical twin bearingless machine system has three fundamental control degrees of freedom that need to be actuated: $\vec{T} = \vec{T}_1 + \vec{T}_2$, \vec{F}_1 , and \vec{F}_2 where the subscripts **1** and **2** are used to denote first bearingless machine **104a** and second bearingless machine **104b**, respectively. It follows then that only three control current space vectors are required, $\vec{i}_t = \vec{i}_{t,1} + \vec{i}_{t,2}$, $\vec{i}_{s,1}$, and $\vec{i}_{s,2}$ that can be realized by regulating the terminal currents of three inverters instead of four inverters. \vec{i}_t indicates a torque current, $\vec{i}_{s,1}$ indicates a first suspension current for first bearingless machine **104a**, and $\vec{i}_{s,2}$ indicates a second suspension current for second bearingless machine **104b**.

[0074] There are many options for connecting three inverters to first bearingless machine **104a** and second bearingless machine **104b**. To simplify this analysis, both first bearingless machine **104a** and second bearingless machine **104b** may be considered to be identical and the space vector equivalent circuit is used so that each machine is depicted as having two coil groups a and b. There are seven unique connection structures as depicted in FIGS. 7A-7G. Each of these structures can form multiple unique drive topologies by changing the inductor symbol that each coil group is assigned to as machine **1** or machine **2** and coil group a or b, a coil group direction (positive orientation), and a node at which each of the three inverters inject current. Each structure includes a first coil **700**, a second coil **702**, a third coil **704**, and a fourth coil **706**, where each coil represents a three-phase stator winding.

[0075] A first coil group structure **708a** is shown referring to FIG. 7A in accordance with an illustrative embodiment. First coil group structure **708a** includes series connected combinations of machine **1** and machine **2** between nodes **1** and **2**, between nodes **2** and **3**, between nodes **3** and **4**, and between nodes **4** and **5**. For example, first coil **700** is connected between nodes **1** and **2**, second coil **702** is connected between nodes **2** and **3**, third coil **704** is connected between nodes **3** and **4**, and fourth coil **706** is connected between nodes **4** and **5** in series.

[0076] A first combination is machine **1**, machine **2**, machine **2**, and machine **1**, respectively. A second combination is machine **1**, machine **2**, machine **1**, and machine **2**, respectively. A third combination is machine **1**, machine **1**, machine **2**, and machine **2**, respectively. Coil group a or b can be assigned to each coil position. First coil group structure **708a** has three unique sets of coil group assignments assuming that 1, 1, 2, 2, is equivalent to 2, 2, 1, 1. Similarly, changing the assignment between coil group a and b does not create a new topology as these coil groups are equivalent. Machine **1** refers to first bearingless machine **104a**, and machine **2** refers to second bearingless machine **104b**.

[0077] In first coil group structure **708a**, first inverter **200a**, second inverter **200b**, and a third inverter **200c** (e.g., shown referring to FIG. 4A) can be connected to any three of the nodes **1** through **5**. For example, first inverter **200a** can be connected to node **1**, second inverter **200b** can be connected to any of the remaining nodes **2-5**, and third inverter **200c** can be connected to any of the remaining nodes not connected to first inverter **200a** or second inverter **200b**. There are many possible permutations for assigning

the three inverters to the five nodes as well as assigning coil group a or b of each machine to first coil **700**, second coil **702**, third coil **704**, and fourth coil **706**.

[0078] A second coil group structure **708b** is shown referring to FIG. 7B in accordance with an illustrative embodiment. Second coil group structure **708b** includes an islanded, or isolated, X node connection and series connected combinations of machine **1** and machine **2** between nodes **1** and **2**, between nodes **2** and **3**, and between nodes **3** and **4**. Nodes designated with "X" can be assigned to any of the three inverters without changing the total number of unique coil group assignments. For example, first coil **700** is islanded as indicated by the X nodes and second coil **702** is connected between nodes **1** and **2**, third coil **704** is connected between nodes **2** and **3**, and fourth coil **706** is connected between nodes **3** and **4** in series. A first combination is machine **1**, machine **2**, machine **1**, and machine **2**, respectively. A second combination is machine **1**, machine **1**, machine **2**, and machine **2**, respectively.

[0079] In second coil group structure **708b**, any two of first inverter **200a**, second inverter **200b**, and third inverter **200c** can be connected to any pair of the nodes **1** through **4** while the remaining inverter is connected to first coil **700**. For example, first inverter **200a** can be connected to first coil **700**, second inverter **200b** can be connected to any of the nodes **1-4**, and third inverter **200c** can be connected to any of the remaining nodes not connected to second inverter **200b**. There are many possible permutations for assigning the three inverters to the four nodes as well as assigning coil group a or b of each machine to first coil **700**, second coil **702**, third coil **704**, and fourth coil **706**.

[0080] A third coil group structure **708c** is shown referring to FIG. 7C in accordance with an illustrative embodiment. Third coil group structure **708c** includes first series connected combinations of machine **1** and machine **2** between nodes **1** and **2** and between nodes **2** and **3** that are islanded relative to second series connected combinations of machine **1** and machine **2** between nodes **4** and **5** and **5** and **6**. For example, first coil **700** is connected between nodes **1** and **2** and second coil **702** is connected between nodes **2** and **3** in series with first coil **700**; third coil **704** is connected between nodes **4** and **5** and fourth coil **706** is connected between nodes **5** and **6** in series with third coil **704**. A first combination is machine **1**, machine **2**, machine **1**, and machine **2**, respectively. A second combination is machine **1**, machine **1**, machine **2**, and machine **2**, respectively.

[0081] In third coil group structure **708c**, one or two of first inverter **200a**, second inverter **200b**, and third inverter **200c** can be connected to any of the nodes **1** through **3** while the remaining inverter(s) is(are) connected to any of the nodes **4** through **6**. For example, first inverter **200a** can be connected to node **1**, second inverter **200b** can be connected to node **4**, and third inverter **200c** can be connected to any of the remaining nodes not connected to first inverter **200a** or second inverter **200b**. There are many possible permutations for assigning the three inverters to the six nodes as well as assigning coil group a or b of each machine to first coil **700**, second coil **702**, third coil **704**, and fourth coil **706**.

[0082] A fourth coil group structure **708d** is shown referring to FIG. 7D in accordance with an illustrative embodiment. Fourth coil group structure **708d** includes the first series connected combinations of machine **1** and machine **2** between nodes **1** and **2** and between nodes **2** and **3**, and two islanded X node connections. For example, first coil **700** is

connected between nodes 1 and 2 and second coil 702 is connected between nodes 2 and 3 in series with first coil 700; third coil 704 is islanded from the other coils, and fourth coil 706 is islanded from the other coils. A first combination is machine 1, machine 1, machine 2 and machine 2, respectively. A second combination is machine 1, machine 2 and either combination of machine 1, and machine 2, respectively.

[0083] In fourth coil group structure 708d, one of first inverter 200a, second inverter 200b, and third inverter 200c is connected to third node 704, one of the remaining inverters is connected to fourth node 706, and the remaining inverter is connected to any of the nodes 1 through 3. For example, first inverter 200a can be connected to any of nodes 1 through 3, second inverter 200b can be connected to third node 704, and third inverter 200c can be connected to fourth node 706. There are many possible permutations for assigning the inverter to the three nodes as well as assigning coil group a or b of each machine to first coil 700, second coil 702, third coil 704, and fourth coil 706.

[0084] A fifth coil group structure 708e is shown referring to FIG. 7E in accordance with an illustrative embodiment. Fifth coil group structure 708e includes the first series connected combinations of machine 1 and machine 2 between nodes 1 and 2, between nodes 2 and 3, and between nodes 3 and 4, and another machine connection between nodes 3 and 5. The “X” above coil means that the coil can be assigned to coil groups “a” and “b” in machine 1 and machine 2. The different selections of “X” are equivalent. Therefore, the selection of “X” will not change the total number of unique coil group assignments. For example, first coil 700 is connected between nodes 1 and 2, second coil 702 is connected between nodes 2 and 3 in series with first coil 700, third coil 704 is connected between nodes 3 and 4 in series with second coil 702, and fourth coil 706 is connected between nodes 3 and 5. Node 3 is a common connection between second coil 702, third coil 704, and fourth coil 706. A first combination is machine 1, machine 1, machine 2, and machine 2, respectively. A second combination is machine 1, machine 2 and either combination of machine 1 and machine 2 between nodes 3 and 4 and between nodes 3 and 5, respectively.

[0085] In fifth coil group structure 708e, first inverter 200a, second inverter 200b, and third inverter 200c can be connected to any three of the nodes 1 through 5. For example, first inverter 200a can be connected to node 1, second inverter 200b can be connected to any of the remaining nodes 2-5, and third inverter 200c can be connected to any of the remaining nodes not connected to first inverter 200a or second inverter 200b. There are many possible permutations for assigning the three inverters to the five nodes as well as assigning coil group a or b of each machine to first coil 700, second coil 702, third coil 704, and fourth coil 706.

[0086] A sixth coil group structure 708f is shown referring to FIG. 7F in accordance with an illustrative embodiment. Sixth coil group structure 708f includes an islanded X node connection, and a series connected combination of machine 1 and machine 2 between nodes 1 and 2 and between nodes 2 and 3 and another machine connection between 2 and 4. For example, first coil 700 is islanded, second coil 702 is connected between nodes 1 and 2, third coil 704 is connected between nodes 2 and 3 in series with second coil 702, and fourth coil 706 is connected between nodes 2 and 4.

Node 2 is a common connection between second coil 702, third coil 704, and fourth coil 706.

[0087] In sixth coil group structure 708f, any two of first inverter 200a, second inverter 200b, and third inverter 200c can be connected to any pair of the nodes 1 through 4 while the remaining inverter is connected to first coil 700. For example, first inverter 200a can be connected to first coil 700, second inverter 200b can be connected to any of the nodes 1-4, and third inverter 200c can be connected to any of the remaining nodes not connected to second inverter 200b. There are many possible permutations for assigning the three inverters to the four nodes as well as assigning coil group a or b of each machine to first coil 700, second coil 702, third coil 704, and fourth coil 706.

[0088] A seventh coil group structure 708g is shown referring to FIG. 7G in accordance with an illustrative embodiment. Seventh coil group structure 708g includes a machine node connection between nodes 1 and 2, between nodes 2 and 3, between nodes 2 and 4, and between nodes 2 and 5. For example, first coil 700 is connected between nodes 1 and 2, second coil 702 is connected between nodes 2 and 3 in series with first coil 700, third coil 704 is connected between nodes 2 and 4, and fourth coil 706 is connected between nodes 2 and 5. Node 2 is a common connection between first coil 700, second coil 702, third coil 704, and fourth coil 706.

[0089] In seventh coil group structure 708g, first inverter 200a, second inverter 200b, and third inverter 200c can be connected to any three of the nodes 1 through 5. For example, first inverter 200a can be connected to node 1, second inverter 200b can be connected to any of the remaining nodes 2-5, and third inverter 200c can be connected to any of the remaining nodes not connected to first inverter 200a or second inverter 200b. There are many possible permutations for assigning the three inverters to the five nodes as well as assigning coil group a or b of each machine to first coil 700, second coil 702, third coil 704, and fourth coil 706.

[0090] Sixth coil group structure 708f and seventh coil group structure 708g include a single unique coil group assignment set. In FIG. 7F, second coil 702, third coil 704, and fourth coil 706 are connected together and form a common node 2. The three coils are equivalent. If the islanded coil, first coil 700 in the illustrative embodiment, is assigned to machine 1, the assignment of the remaining three coils does not influence the total number of unique structures. Thus, only one unique structure can be formed when first coil 700 is assigned to machine 1. Furthermore, machine 1 and machine 2 are equivalent and interchangeable. In the case of first coil 700 being assigned to machine 2, the structure is no different from that in the case of first coil 700 being assigned to machine 1. As a result, there is only one unique structure for sixth coil group structure 708f and, similarly, for seventh coil group structure 708g.

[0091] Reversing the connection direction of any coil group results in a unique configuration. Since there are four coil groups (coil group a and b of machine 1 and 2), there are $2^4=16$ variations within each set of coil group assignments. The circuit nodes of FIGS. 7A-7G are indicated with the dots. Unique topologies are created for each coil group assignment of each structure by assigning the three inverters to different combinations of the nodes. No more than one inverter may be assigned to a single node. For coil groups that are islanded, an inverter may be placed at one of the

nodes and a neutral point is placed at the other node. Therefore, both nodes are indicated with "X" in FIGS. 7A-7G. Each set of inverter node assignments requires a unique placement of neutral points at other nodes to ensure that current can reach all coil groups. Based on the formula for combinations, there are 1,393 possible arrangements that can be formed.

[0092] Referring to FIGS. 4A-4J, stator winding connections to first inverter **200a**, second inverter **200b**, and third inverter **200c** are shown for first bearingless machine **104a** and second bearingless machine **104b** in accordance with an illustrative embodiment. u_{a1} , u_{b1} , v_{a1} , v_{b1} , w_{a1} , w_{b1} are the three-phase windings u, v, w of coil groups a and b of first bearingless machine **104a**. u_{a2} , u_{b2} , v_{a2} , v_{b2} , w_{a2} , w_{b2} are the three-phase windings u, v, w of coil groups a and b of second bearingless machine **104b**.

[0093] Referring to FIG. 4A, a first stator winding connection **400a** is shown that includes a first stator winding **402a** and a second stator winding **402b**. First stator winding **402a** connects u_{a1} , u_{b1} , v_{a1} , v_{b1} , and w_{a1} , w_{b1} between first inverter **200a**, second inverter **200b**, and a first neutral connector **404a**. Second stator winding **402b** connects u_{a2} , u_{b2} , v_{a2} , v_{b2} , and w_{a2} , w_{b2} between third inverter **200c**, the respective phase windings of first stator winding **402a**, and a second neutral connector **404b**. First stator winding connection **400a** is an example of first coil group structure **708a**.

[0094] Referring to FIG. 5, a second space-vector diagram **500** is shown for first stator winding connection **400a** in accordance with an illustrative embodiment. First inverter **200a**, second inverter **200b**, and third inverter **200c** are denoted using current sources \vec{i}_1 , \vec{i}_2 , and \vec{i}_3 , and neutral points are indicated using ground symbols. Second space-vector diagram **500** indicates first voltage source **302a**, first back EMF **304a**, first resistor **306a**, first inductor **308a**, first mutual inductance **310a**, second voltage source **302b**, second back EMF **304b**, second resistor **306b**, second inductor **308b**, and second mutual inductance **310b** of first stator winding connection **400a** for each phase of first bearingless machine **104a**. A third voltage source **302c**, a third back EMF **304c**, a third resistor **306c**, a third inductor **308c**, a third mutual inductance **310c**, a fourth back EMF **304d**, a fourth resistor **306d**, a fourth inductor **308d**, and a fourth mutual inductance **310d** of second stator winding **402b** for each phase. Currents \vec{i}_{a1} , \vec{i}_{b1} , \vec{i}_{a2} , and \vec{i}_{b2} are also indicated. The dotted inductors represent a polarity of mutual inductance that corresponds to the dotted terminals of FIG. 4A.

[0095] For each coil group structure of FIGS. 7A-7G, the machines' coil group current space vectors (\vec{i}_{a1} , \vec{i}_{a2} , \vec{i}_{b1} , \vec{i}_{b2}) can be calculated in terms of the inverter currents (\vec{i}_1 , \vec{i}_2 , \vec{i}_3) and expressed as a matrix

$$\begin{bmatrix} \vec{i}_{a1} \\ \vec{i}_{a2} \\ \vec{i}_{b1} \\ \vec{i}_{b2} \end{bmatrix} = T_c \begin{bmatrix} \vec{i}_1 \\ \vec{i}_2 \\ \vec{i}_3 \end{bmatrix} \quad (1)$$

[0096] The matrix T_c is unique for each coil group structure and can be obtained from the structure's space vector circuit by using superposition and writing Kirchhoff's Cur-

rent Law expressions. The control currents $\vec{i}_r = \vec{i}_{r,1} + \vec{i}_{r,2}$, $\vec{i}_{s,1}$, and $\vec{i}_{s,2}$ are determined using $\vec{i}_r = \vec{i}_a + \vec{i}_b = 2\vec{i}_r e^{j\theta}$, and $\vec{i}_s = 0.5(\vec{i}_b - \vec{i}_a) = \vec{i}_s e^{j\theta_s}$ as

$$\begin{bmatrix} \vec{i}_{s,1} \\ \vec{i}_{s,2} \\ \vec{i}_r \end{bmatrix} = T_F \begin{bmatrix} \vec{i}_{a1} \\ \vec{i}_{a2} \\ \vec{i}_{b1} \\ \vec{i}_{b2} \end{bmatrix} T_F = \begin{bmatrix} -\frac{1}{2} & \frac{1}{2} & 0 & 0 \\ 0 & 0 & -\frac{1}{2} & \frac{1}{2} \\ 1 & 1 & 1 & 1 \end{bmatrix} \quad (2)$$

where the required inverter terminal currents necessary to obtain the desired control currents can be obtained when $T_F T_c$ is invertible using

$$\begin{bmatrix} \vec{i}_1 \\ \vec{i}_2 \\ \vec{i}_3 \end{bmatrix} = (T_F T_c)^{-1} \begin{bmatrix} \vec{i}_{s,1} \\ \vec{i}_{s,2} \\ \vec{i}_r \end{bmatrix}$$

The coil group currents are then calculated in terms of the control currents. Applying this to second space-vector diagram **500** results in

$$T_c = \begin{bmatrix} 1/2 & 3/4 & 1/4 \\ 1/2 & -1/4 & 1/4 \\ 1/2 & 1/4 & 3/4 \\ 1/2 & 1/4 & -1/4 \end{bmatrix}$$

$$\vec{i}_{a1} = \frac{1}{4}\vec{i}_r - \vec{i}_{s,1}, \vec{i}_{b1} = \frac{1}{4}\vec{i}_r + \vec{i}_{s,1}, \vec{i}_{a2} = \frac{1}{4}\vec{i}_r - \vec{i}_{s,2}, \vec{i}_{b2} = \frac{1}{4}\vec{i}_r + \vec{i}_{s,2}$$

$$\vec{i}_1 = \frac{1}{2}\vec{i}_r + \vec{i}_{s,1} + \vec{i}_{s,2}, \vec{i}_2 = -2\vec{i}_{s,1}, \vec{i}_3 = -2\vec{i}_{s,2}$$

[0097] Voltage equations can be derived for each set of inverter terminals to design current regulators and can be used to determine the voltage requirement of each inverter. Each inverter's voltage equation can be determined by applying Kirchhoff's Voltage Law (KVL) around a loop from the inverter of interest to the nearest neutral point in a manner that does not pass through another inverter.

[0098] For example, applying this to second space-vector diagram **500** results in the inverter voltage expressions

$$\vec{v}_1 = R(\vec{i}_{a1} + \vec{i}_{b1}) + (L + M) \frac{d}{dt}(\vec{i}_{a1} + \vec{i}_{b1}) + 2\vec{v}_m$$

$$\vec{v}_2 = R\vec{i}_{a1} + L \frac{d}{dt}\vec{i}_{a1} + M \frac{d}{dt}\vec{i}_{b1} + \vec{v}_m$$

$$\vec{v}_3 = R\vec{i}_{a2} + L \frac{d}{dt}\vec{i}_{a2} + M \frac{d}{dt}\vec{i}_{b2} + \vec{v}_m$$

where the term \vec{v}_m represents the back-EMF of the machine that appears within a coil group, \vec{i}_{a1} , \vec{i}_{b1} , \vec{i}_{a2} , and \vec{i}_{b2} represent the current in each respective coil group, and \vec{v}_1 , \vec{v}_2 , and \vec{v}_3 represent the voltage in each respective inverter. In this coil group structure, first inverter **200a** is exposed to

more back-EMF ($2\vec{v}_m$) as compared to second inverter **200b** and third inverter **200c** (\vec{v}_m) and will likely require higher voltage electronics.

[0099] Because first bearingless machine **104a** and second bearingless machine **104b** are identical, R indicates a resistance of first resistor **306a**, second resistor **306b**, third resistor **306c**, and fourth resistor **306d**; L indicates an inductance of first inductor **308a**, second inductor **308b**, third inductor **308c**, and fourth inductor **308d**; M indicates a mutual inductance of first mutual inductance **310a**, second mutual inductance **310b**, third mutual inductance **310c**, and fourth mutual inductance **310d**; and \vec{v}_m indicates a back-EMF of first back EMF **304a**, second back EMF **304b**, third back EMF **304c**, and fourth back EMF **304d**.

[0100] Referring to FIG. 6A, a circuit diagram for first stator winding connection **400a** is shown in accordance with an illustrative embodiment. Referring to FIG. 6B, a zoomed view of the circuit diagram FIG. 6A showing first inverter **200a** and second inverter **200b** is shown in accordance with an illustrative embodiment. Referring to FIG. 6C, a zoomed view of the circuit diagram FIG. 6A showing first inverter **200a** and third inverter **200c** is shown in accordance with an illustrative embodiment.

[0101] A machine voltage source **600** is connected in parallel across a capacitor **602**, first inverter **200a**, second inverter **200b**, and third inverter **200c** between a first line **610** and a second line **612**. First stator winding connection **400a** includes a first phase, first machine, first winding **604ua1**, a second phase, first machine, first winding **604va1**, a third phase, first machine, first winding **604wa1**, a first phase, first machine, second winding **604ub1**, a second phase, first machine, second winding **604vb1**, a third phase, first machine, second winding **604wb1**, first neutral connector **404a**, a first phase, second machine, first winding **604ua2**, a second phase, second machine, first winding **604va2**, a third phase, second machine, first winding **604wa2**, a first phase, second machine, second winding **604ub2**, a second phase, second machine, second winding **604vb2**, a third phase, second machine, second winding **604wb2**, and second neutral connector **404b**.

[0102] A first phase line **614u** connects first phase, first machine, first winding **604ua1**, first phase, first machine, second winding **604ub1**, first phase, second machine, second winding **604ub2**, and first phase, second machine, first winding **604ua2** in series between first neutral connector **404a** and second neutral connector **404b**. A second phase line **614v** connects second phase, first machine, first winding **604va1**, second phase, first machine, second winding **604vb1**, second phase, second machine, second winding **604vb2**, and second phase, second machine, first winding **604va2** in series between first neutral connector **404a** and second neutral connector **404b**. A third phase line **614w** connects third phase, first machine, first winding **604wa1**, third phase, first machine, second winding **604wb1**, third phase, second machine, second winding **604wb2**, and third phase, second machine, first winding **604wa2** in series between first neutral connector **404a** and second neutral connector **404b**.

[0103] First inverter **200a** may include a first phase, first inverter, first transistor **608u11**, a first phase, first inverter, second transistor **608u21**, a second phase, first inverter, first transistor **608v11**, a second phase, first inverter, second transistor **608v21**, a third phase, first inverter, first transistor

608w11, and a third phase, first inverter, second transistor **608w21**. First phase, first inverter, first transistor **608u11** and first phase, first inverter, second transistor **608u21** are connected in series between first line **610** and second line **612** as understood by a person of skill in the art. A portion of first phase line **614u** between first phase, first machine, second winding **604ub1** and first phase, second machine, second winding **604ub2** is connected between first phase, first inverter, first transistor **608u11** and first phase, first inverter, second transistor **608u21**.

[0104] Similarly, second phase, first inverter, first transistor **608v11** and second phase, first inverter, second transistor **608v21** are connected in series between first line **610** and second line **612**. A portion of second phase line **614v** between second phase, first machine, second winding **604vb1** and second phase, second machine, second winding **604vb2** is connected between second phase, first inverter, first transistor **608v11** and second phase, first inverter, second transistor **608v21**.

[0105] Similarly, third phase, first inverter, first transistor **608w11** and third phase, first inverter, second transistor **608w21** are connected in series between first line **610** and second line **612**. A portion of third phase line **614w** between third phase, first machine, second winding **604wb1** and third phase, second machine, second winding **604wb2** is connected between third phase, first inverter, first transistor **608w11** and third phase, first inverter, second transistor **608w21**.

[0106] Second inverter **200b** may include a first phase, second inverter, first transistor **608u12**, a first phase, second inverter, second transistor **608u22**, a second phase, second inverter, first transistor **608v12**, a second phase, second inverter, second transistor **608v22**, a third phase, second inverter, first transistor **608w12**, and a third phase, second inverter, second transistor **608w22**. First phase, second inverter, first transistor **608u12** and first phase, second inverter, second transistor **608u22** are connected in series between first line **610** and second line **612** as understood by a person of skill in the art. A portion of first phase line **614u** between first phase, first machine, first winding **604ua1** and first phase, first machine, second winding **604ub1** is connected between first phase, second inverter, first transistor **608u12** and first phase, second inverter, second transistor **608u22**.

[0107] Similarly, second phase, second inverter, first transistor **608v12** and second phase, second inverter, second transistor **608v22** are connected in series between first line **610** and second line **612**. A portion of second phase line **614v** between second phase, first machine, first winding **604va1** and second phase, first machine, second winding **604vb1** is connected between second phase, second inverter, first transistor **608v12** and second phase, second inverter, second transistor **608v22**.

[0108] Similarly, third phase, second inverter, first transistor **608w12** and third phase, second inverter, second transistor **608w22** are connected in series between first line **610** and second line **612**. A portion of third phase line **614w** between third phase, first machine, first winding **604wa1** and third phase, first machine, second winding **604wb1** is connected between third phase, second inverter, first transistor **608w12** and third phase, second inverter, second transistor **608w22**.

[0109] Third inverter **200c** may include a first phase, third inverter, first transistor **608u13**, a first phase, third inverter,

second transistor **608u23**, a second phase, third inverter, first transistor **608v13**, a second phase, third inverter, second transistor **608v23**, a third phase, third inverter, first transistor **608w13**, and a third phase, third inverter, second transistor **608w23**. First phase, third inverter, first transistor **608u13** and first phase, third inverter, second transistor **608u23** are connected in series between first line **610** and second line **612** as understood by a person of skill in the art. A portion of first phase line **614u** between first phase, second machine, second winding **604ub2** and first phase, second machine, first winding **604ua2** is connected between first phase, third inverter, first transistor **608u13** and first phase, third inverter, second transistor **608u23**.

[0110] Similarly, second phase, third inverter, first transistor **608v13** and second phase, second inverter, second transistor **608v23** are connected in series between first line **610** and second line **612**. A portion of second phase line **614v** between second phase, second machine, second winding **604vb2** and second phase, second machine, first winding **604va2** is connected between second phase, third inverter, first transistor **608v13** and second phase, third inverter, second transistor **608v23**.

[0111] Similarly, third phase, third inverter, first transistor **608w13** and third phase, second inverter, second transistor **608w23** are connected in series between first line **610** and second line **612**. A portion of third phase line **614w** between third phase, second machine, second winding **604wb2** and third phase, second machine, first winding **604a2** is connected between third phase, third inverter, first transistor **608w12** and third phase, third inverter, second transistor **608w23**.

[0112] A half-bridge is included for each phase output from first inverter **200a**, second inverter **200b**, and third inverter **200c**. Each half bridge includes a first transistor such as first phase, second inverter, first transistor **608u12** and a second transistor such as first phase, second inverter, second transistor **608u22** with the phase line to a stator winding therebetween as understood by a person of skill in the art.

[0113] Referring again to FIG. 4A, in first stator winding **402a**, the positive terminal of first machine, second winding is connected to a respective phase terminal of first inverter **200a** and the negative terminal of first machine, second winding is connected to the positive terminal of first machine, first winding and the negative terminal of first machine, first winding is connected to first neutral connector **404a**. The positive terminal of first machine, first winding is also connected to a respective phase terminal of second inverter **200b**. In second stator winding **402b**, the positive terminal of second machine, second winding is connected to a respective phase terminal of first inverter **200a** and the negative terminal of second machine, second winding is connected to the positive terminal of second machine, first winding and the negative terminal of second machine, first winding is connected to second neutral connector **404b**. The positive terminal of second machine, first winding is also connected to a respective phase terminal of third inverter **200c**.

[0114] In summary, in the illustrative configuration of FIGS. 4A, 5, and 6A, each respective phase winding is connected in series in the order, first neutral connector **404a**, the first machine, first winding followed by the first machine, second winding followed by the second machine, second winding followed by the second machine, first wind-

ing followed by second neutral connector **404b**. Second inverter **200b** is connected between the first machine, first winding and the first machine, second winding. First inverter **200a** is connected between the first machine, second winding and the second machine, second winding. Third inverter **200c** is connected between the second machine, second winding and the second machine, first winding.

[0115] As understood by a person of skill in the art, each transistor may include a drain, a gate, and a source like a metal-oxide-semiconductor field-effect transistor (MOSFET) or include a collector, a gate, and an emitter like an insulated-gate bipolar transistor (IGBT), or include a collector, a base, and an emitter like a bipolar junction transistor (BJT). Depending on the switching logic and whether each transistor is an n-type or a p-type, the drain and the source may be reversed. A voltage or current applied to the gate or base determines a switching state of each transistor. Controller **110** continuously provides gate signals to control a state of each transistor to generate the inverter currents. At any point in time, only one of the first transistor and the second transistor of each half-bridge is effectively closed.

[0116] Referring to FIG. 4B, a second stator winding connection **400b** is shown that includes first stator winding **402a** and second stator winding **402b**. First stator winding **402a** connects u_{a1} , u_{b1} , v_{a1} , v_{b1} , and w_{a1} , w_{b1} between first inverter **200a** and second inverter **200b**. Second stator winding **402b** connects u_{a2} , u_{b2} , v_{a2} , v_{b2} , and w_{a2} , w_{b2} between third inverter **200c** and the respective phase windings of first stator winding **402a**. Second stator winding connection **400b** is a second example of first coil group structure **708a**.

[0117] In the illustrative configuration of FIG. 4B, in first stator winding **402a**, the positive terminal of first machine, first winding is connected to the respective phase terminal of first inverter **200a** and the negative terminal of first machine, first winding is connected to the positive terminal of first machine, second winding and to a respective phase terminal of second inverter **200b**. The negative terminal of first machine, second winding is also connected to the positive terminal of second machine, second winding. In second stator winding **402b**, the negative terminal of second machine, second winding is connected to a respective phase terminal of third inverter **200c** and the negative terminal of second machine, first winding. The negative terminal of second machine, first winding is connected to first neutral connector **404a**.

[0118] For second stator winding connection **400b**,

$$T_c = \begin{bmatrix} 1 & 0 & 0 \\ 1 & 1 & 0 \\ 1 & 1 & 1 \\ 1 & 1 & 0 \end{bmatrix}$$

$$\vec{i}_{a1} = \frac{1}{4}\vec{i}_r - \frac{3}{2}\vec{i}_{s,1} + \frac{1}{2}\vec{i}_{s,2}, \quad \vec{i}_{b1} = \frac{1}{4}\vec{i}_r + \frac{1}{2}\vec{i}_{s,1} + \frac{1}{2}\vec{i}_{s,2},$$

$$\vec{i}_{a2} = \frac{1}{4}\vec{i}_r + \frac{1}{2}\vec{i}_{s,1} - \frac{3}{2}\vec{i}_{s,2},$$

$$\vec{i}_{b2} = \frac{1}{4}\vec{i}_r + \frac{1}{2}\vec{i}_{s,1} + \frac{1}{2}\vec{i}_{s,2}$$

$$\vec{i}_1 = \frac{1}{4}\vec{i}_r - \frac{3}{2}\vec{i}_{s,1} + \frac{1}{2}\vec{i}_{s,2}, \quad \vec{i}_2 = 2\vec{i}_{s,1}, \quad \vec{i}_3 = -2\vec{i}_{s,2}$$

[0119] Referring to FIG. 4C, a third stator winding connection **400c** is shown that includes a first stator MP winding

402c, a second stator MP winding **402d**, and second stator winding **402b**. First stator MP winding **402c** connects u_{a1} , v_{a1} , and w_{a1} to first inverter **200a**. Second stator winding **402b** connects u_{a2} , u_{b2} , v_{a2} , v_{b2} , and w_{a2} , w_{b2} between third inverter **200c** and the respective phase windings of second stator MP winding **402d**. Third stator winding connection **400c** is an example of second coil group structure **708b**.

[0120] In the illustrative configuration of FIG. 4C, the positive terminal of first machine, first winding is connected to the respective phase terminal of first inverter **200a** and the negative terminal of first machine, first winding is connected to first neutral connector **404a**. In second stator winding **402b**, the positive terminal of second machine, first winding is connected to the respective phase terminal of third inverter **200c** and the negative terminal of second machine, first winding is connected to the negative terminal of second machine, second winding. The positive terminal of second machine, second winding is connected to the negative terminal of first machine, second winding. The negative terminal of first machine, second winding is connected to second neutral connector **404b**. The negative terminal of second machine, first winding and of second machine, second winding is connected to the respective phase terminal of second inverter **200b**.

[0121] Referring to FIG. 8A, a third space-vector diagram **800a** is shown for third stator winding connection **400c** in accordance with an illustrative embodiment. For third stator winding connection **400c**,

$$T_c = \begin{bmatrix} 1 & 0 & 0 \\ 0 & -1 & -1 \\ 0 & 0 & 1 \\ 0 & -1 & -1 \end{bmatrix}$$

$$\vec{i}_{a1} = \frac{1}{4}\vec{i}_r - \frac{3}{2}\vec{i}_{s,1} + \frac{1}{2}\vec{i}_{s,2}, \vec{i}_{b1} = \frac{1}{4}\vec{i}_r + \frac{1}{2}\vec{i}_{s,1} + \frac{1}{2}\vec{i}_{s,2},$$

$$\vec{i}_{a2} = \frac{1}{4}\vec{i}_r + \frac{1}{2}\vec{i}_{s,1} - \frac{3}{2}\vec{i}_{s,2},$$

$$\vec{i}_{b2} = \frac{1}{4}\vec{i}_r + \frac{1}{2}\vec{i}_{s,1} + \frac{1}{2}\vec{i}_{s,2}$$

$$\vec{i}_1 = \frac{1}{4}\vec{i}_r - \frac{3}{2}\vec{i}_{s,1} + \frac{1}{2}\vec{i}_{s,2}, \vec{i}_2 = -\frac{1}{2}\vec{i}_r - \vec{i}_{s,1} + \vec{i}_{s,2},$$

$$\vec{i}_3 = \frac{1}{4}\vec{i}_r + \frac{1}{2}\vec{i}_{s,1} - \frac{3}{2}\vec{i}_{s,2}$$

[0122] Referring to FIG. 4D, a fourth stator winding connection **400d** is shown that includes a third stator winding **402g** and a fourth stator winding **402h**. Third stator winding **402g** connects u_{a1} , u_{a2} , v_{a1} , v_{a2} , and w_{a1} , w_{a2} between first inverter **200a** and first neutral connector **404a**. Fourth stator winding **402h** connects u_{b1} , u_{b2} , v_{b1} , v_{b2} , and w_{b1} , w_{b2} between third inverter **200c** and second inverter **200b**. Fourth stator winding connection **400d** is an example of third coil group structure **708c**.

[0123] In third stator winding **402g**, the negative terminal of first machine, first winding is connected to the respective phase terminal of first inverter **200a** and the positive terminal of first machine, first winding is connected to the positive terminal of second machine, first winding. The negative terminal of second machine, first winding is connected to first neutral connector **404a**. In fourth stator winding **402h**, the negative terminal of second machine, second winding is connected to the respective phase terminal of third inverter **200c** and the positive terminal of second machine, second

winding is connected to the positive terminal of first machine, second winding and to the respective phase terminal of second inverter **200b**. The negative terminal of first machine, second winding is connected to second neutral connector **404b**.

[0124] Referring to FIG. 8B, a fourth space-vector diagram **800b** is shown for fourth stator winding connection **400d** in accordance with an illustrative embodiment. For fourth stator winding connection **400d**,

$$T_c = \begin{bmatrix} 1 & 0 & 0 \\ 0 & 1 & 1 \\ 1 & 0 & 0 \\ 0 & 0 & -1 \end{bmatrix}$$

$$\vec{i}_{a1} = \frac{1}{4}\vec{i}_r - \frac{1}{2}\vec{i}_{s,1} - \frac{1}{2}\vec{i}_{s,2}, \vec{i}_{b1} = \frac{1}{4}\vec{i}_r + \frac{3}{2}\vec{i}_{s,1} - \frac{1}{2}\vec{i}_{s,2},$$

$$\vec{i}_{a2} = \frac{1}{4}\vec{i}_r - \frac{1}{2}\vec{i}_{s,1} - \frac{1}{2}\vec{i}_{s,2},$$

$$\vec{i}_{b2} = \frac{1}{4}\vec{i}_r - \frac{1}{2}\vec{i}_{s,1} + \frac{3}{2}\vec{i}_{s,2}$$

$$\vec{i}_1 = \frac{1}{4}\vec{i}_r - \frac{1}{2}\vec{i}_{s,1} - \frac{1}{2}\vec{i}_{s,2}, \vec{i}_2 = \frac{1}{2}\vec{i}_r + \vec{i}_{s,1} + \vec{i}_{s,2},$$

$$\vec{i}_3 = -\frac{1}{4}\vec{i}_r + \frac{1}{2}\vec{i}_{s,1} - \frac{3}{2}\vec{i}_{s,2}$$

[0125] Referring to FIG. 4E, a fifth stator winding connection **400e** is shown that includes second stator MP winding **402d**, third stator winding **402g** and a third stator MP winding **402f**. Second stator MP winding **402d** connects u_{b1} , v_{b1} , and w_{b1} between first inverter **200a** and first neutral connector **404a**. Third stator winding **402g** connects u_{a1} , u_{a2} , v_{a1} , v_{a2} , and w_{a1} , w_{a2} between second inverter **200b** and second neutral connector **404b**. Third stator MP winding **402f** connects u_{b2} , v_{b2} , and w_{b2} between third inverter **200c** and a third neutral connector **404c**. Fifth stator winding connection **400e** is an example of fourth coil group structure **708d**.

[0126] In third stator winding **402g**, the negative terminal of first machine, first winding is connected to a respective phase terminal of second inverter **200b** and the positive terminal of first machine, first winding is connected to the positive terminal of second machine, first winding. The negative terminal of second machine, first winding is connected to second neutral connector **404b**. In second stator MP winding **402d**, the positive terminal of first machine, second winding is connected to a respective phase terminal of first inverter **200a** and the negative terminal of first machine, second winding is connected to first neutral connector **404a**. In third stator MP winding **402f**, the positive terminal of second machine, second winding is connected to a respective phase terminal of third inverter **200c** and the negative terminal of second machine, second winding is connected to third neutral connector **404c**.

[0127] Referring to FIG. 8C, a fifth space-vector diagram **800c** is shown for fifth stator winding connection **400e** in accordance with an illustrative embodiment. For fifth stator winding connection **400e**,

$$T_c = \begin{bmatrix} 0 & 1 & 0 \\ 1 & 0 & 0 \\ 0 & 1 & 0 \\ 0 & 0 & 1 \end{bmatrix}$$

-continued

$$\vec{i}_{a1} = \frac{1}{4}\vec{i}_r - \frac{1}{2}\vec{i}_{s,1} - \frac{1}{2}\vec{i}_{s,2}, \vec{i}_{b1} = \frac{1}{4}\vec{i}_r + \frac{3}{2}\vec{i}_{s,1} - \frac{1}{2}\vec{i}_{s,2},$$

$$\vec{i}_{a2} = \frac{1}{4}\vec{i}_r - \frac{1}{2}\vec{i}_{s,1} - \frac{1}{2}\vec{i}_{s,2},$$

$$\vec{i}_{b2} = \frac{1}{4}\vec{i}_r - \frac{1}{2}\vec{i}_{s,1} + \frac{3}{2}\vec{i}_{s,2}$$

$$\vec{i}_1 = \frac{1}{4}\vec{i}_r + \frac{3}{2}\vec{i}_{s,1} - \frac{1}{2}\vec{i}_{s,2}, \vec{i}_2 = \frac{1}{4}\vec{i}_r - \frac{1}{2}\vec{i}_{s,1} - \frac{1}{2}\vec{i}_{s,2},$$

$$\vec{i}_3 = \frac{1}{4}\vec{i}_r - \frac{1}{2}\vec{i}_{s,1} + \frac{3}{2}\vec{i}_{s,2}$$

[0128] Referring to FIG. 4F, a sixth stator winding connection 400f is shown that includes third stator winding 402g and fourth stator winding 402h. Third stator winding 402g connects u_{a1} , u_{a2} , v_{a1} , v_{a2} , and w_{a1} , w_{a2} between first inverter 20a and fourth stator winding 402h. Fourth stator winding 402h connects u_{b1} , u_{b2} , v_{b1} , v_{b2} , and w_{b1} , w_{b2} between third inverter 200c and second inverter 200b. Sixth stator winding connection 400f is an example of fifth coil group structure 708e.

[0129] In third stator winding 402g, the negative terminal of first machine, first winding is connected to the respective phase terminal of first inverter 200a and the positive terminal of first machine, first winding is connected to the positive terminal of second machine, first winding. The negative terminal of second machine, first winding is connected to the negative terminal of first machine, second winding and of second machine, second winding. The negative terminal of second machine, first winding is also connected to the respective phase terminal of second inverter 200b. In fourth stator winding 402h, the positive terminal of first machine, second winding is connected to a respective phase terminal of third inverter 200c and the negative terminal of first machine, second winding is connected to the negative terminal of second machine, second winding. The positive terminal of second machine, second winding is connected to first neutral connector 404a.

[0130] Referring to FIG. 8D, a sixth space-vector diagram 800d is shown for sixth stator winding connection 400f in accordance with an illustrative embodiment. For sixth stator winding connection 400f,

$$T_c = \begin{bmatrix} 1 & 0 & 0 \\ 0 & 0 & 1 \\ 1 & 0 & 0 \\ -1 & -1 & -1 \end{bmatrix}$$

$$\vec{i}_{a1} = \frac{1}{4}\vec{i}_r - \frac{1}{2}\vec{i}_{s,1} - \frac{1}{2}\vec{i}_{s,2}, \vec{i}_{b1} = \frac{1}{4}\vec{i}_r + \frac{3}{2}\vec{i}_{s,1} - \frac{1}{2}\vec{i}_{s,2},$$

$$\vec{i}_{a2} = \frac{1}{4}\vec{i}_r - \frac{1}{2}\vec{i}_{s,1} - \frac{1}{2}\vec{i}_{s,2},$$

$$\vec{i}_{b2} = \frac{1}{4}\vec{i}_r - \frac{1}{2}\vec{i}_{s,1} + \frac{3}{2}\vec{i}_{s,2}$$

$$\vec{i}_1 = \frac{1}{4}\vec{i}_r - \frac{1}{2}\vec{i}_{s,1} - \frac{1}{2}\vec{i}_{s,2}, \vec{i}_2 = -\frac{3}{4}\vec{i}_r - \frac{1}{2}\vec{i}_{s,1} - \frac{1}{2}\vec{i}_{s,2},$$

$$\vec{i}_3 = \frac{1}{4}\vec{i}_r + \frac{3}{2}\vec{i}_{s,1} - \frac{1}{2}\vec{i}_{s,2}$$

[0131] Referring to FIG. 4G, a seventh stator winding connection 400g is shown that includes first stator MP winding 402c, second stator MP winding 402d, and second stator winding 402b. First stator MP winding 402c connects

u_{a1} , v_{a1} , and w_{a1} between first inverter 200a and first neutral connector 404a. Second stator winding 402b connects u_{a2} , u_{b2} , v_{a2} , v_{b2} , and w_{a2} , w_{b2} between third inverter 200c and the respective phase windings of second stator MP winding 402d and second inverter 200b. Second stator MP winding 402d connects u_{b1} , v_{b1} , and w_{b1} between second inverter 200b and third neutral connector 404c. Seventh stator winding connection 400g is an example of sixth coil group structure 708f.

[0132] In first stator MP winding 402c, the negative terminal of first machine, first winding is connected to the respective phase terminal of first inverter 200a and the positive terminal of first machine, first winding is connected to first neutral connector 404a. In second stator MP winding 402d, the negative terminal of first machine, second winding is connected to a respective phase terminal of second inverter 200b and the positive terminal of first machine, second winding is connected to third neutral connector 404c. In second stator winding 402b, the positive terminal of second machine, first winding is connected to a respective phase terminal of third inverter 200c and the negative terminal of second machine, first winding is connected to the negative terminal of second machine, second winding and to the negative terminal of first machine, second winding. The positive terminal of second machine, second winding is connected to second neutral connector 404b. The positive terminal of second machine, second winding is connected to second neutral connector 404b.

[0133] Referring to FIG. 8E, a seventh space-vector diagram 800e is shown for seventh stator winding connection 400g in accordance with an illustrative embodiment. For seventh stator winding connection 400g,

$$T_c = \begin{bmatrix} -1 & 0 & 0 \\ 0 & -1/2 & -1/2 \\ 0 & 0 & 1 \\ 0 & -1/2 & -1/2 \end{bmatrix}$$

$$\vec{i}_{a1} = \frac{1}{4}\vec{i}_r - \frac{3}{2}\vec{i}_{s,1} + \frac{1}{2}\vec{i}_{s,2}, \vec{i}_{b1} = \frac{1}{4}\vec{i}_r + \frac{1}{2}\vec{i}_{s,1} + \frac{1}{2}\vec{i}_{s,2},$$

$$\vec{i}_{a2} = \frac{1}{4}\vec{i}_r + \frac{1}{2}\vec{i}_{s,1} - \frac{3}{2}\vec{i}_{s,2},$$

$$\vec{i}_{b2} = \frac{1}{4}\vec{i}_r + \frac{1}{2}\vec{i}_{s,1} + \frac{1}{2}\vec{i}_{s,2}$$

$$\vec{i}_1 = -\frac{1}{4}\vec{i}_r + \frac{3}{2}\vec{i}_{s,1} - \frac{1}{2}\vec{i}_{s,2}, \vec{i}_2 = -\frac{3}{4}\vec{i}_r - \frac{3}{2}\vec{i}_{s,1} + \frac{1}{2}\vec{i}_{s,2},$$

$$\vec{i}_3 = \frac{1}{4}\vec{i}_r + \frac{1}{2}\vec{i}_{s,1} - \frac{3}{2}\vec{i}_{s,2}$$

[0134] Referring to FIG. 4H, an eighth stator winding connection 400h is shown that includes first stator winding 402a and second stator winding 402b. First stator winding 402a connects u_{a1} , u_{b1} , v_{a1} , v_{b1} , and w_{a1} , w_{b1} between first inverter 200a and second inverter 200b. Second stator winding 402b connects u_{a2} , u_{b2} , v_{a2} , v_{b2} , and w_{a2} , w_{b2} between third inverter 200c and the respective phase windings of first stator winding 402a. Eighth stator winding connection 400h is an example of seventh coil group structure 708g.

[0135] In first stator winding 402a, the negative terminal of first machine, second winding is connected to the respective phase terminal of first inverter 200a and the positive terminal of first machine, second winding is connected to the

positive terminal of first machine, first winding. The positive terminal of first machine, first winding is connected to first neutral connector **404a**. The positive terminal of first machine, first winding and of first machine, second winding is also connected to the respective phase terminal of second inverter **200b**. In second stator winding **402b**, the negative terminal of second machine, second winding is connected to a respective phase terminal of third inverter **200c** and the positive terminal of second machine, second winding is connected to the positive terminal of second machine, first winding. The negative terminal of second machine, first winding is connected to second neutral connector **404b**. The positive terminal of second machine, first winding and of second machine, second winding is also connected to the respective phase terminal of second inverter **200b**.

[0136] Referring to FIG. 8F, an eighth space-vector diagram **800f** is shown for eighth stator winding connection **400h** in accordance with an illustrative embodiment. For eighth stator winding connection **400h**,

$$T_c = \begin{bmatrix} 1/2 & 1/2 & 1/2 \\ -1 & 0 & 0 \\ 1/2 & 1/2 & 1/2 \\ 0 & 0 & -1 \end{bmatrix}$$

$$\vec{i}_{a1} = \frac{1}{4}\vec{i}_r - \frac{1}{2}\vec{i}_{s,1} - \frac{1}{2}\vec{i}_{s,2}, \vec{i}_{b1} = \frac{1}{4}\vec{i}_r + \frac{3}{2}\vec{i}_{s,1} - \frac{1}{2}\vec{i}_{s,2},$$

$$\vec{i}_{a2} = \frac{1}{4}\vec{i}_r - \frac{1}{2}\vec{i}_{s,1} - \frac{1}{2}\vec{i}_{s,2},$$

$$\vec{i}_{b2} = \frac{1}{4}\vec{i}_r - \frac{1}{2}\vec{i}_{s,1} + \frac{3}{2}\vec{i}_{s,2}$$

$$\vec{i}_1 = -\frac{1}{4}\vec{i}_r - \frac{3}{2}\vec{i}_{s,1} + \frac{1}{2}\vec{i}_{s,2}, \vec{i}_2 = \vec{i}_r, \vec{i}_3 = -\frac{1}{4}\vec{i}_r + \frac{1}{2}\vec{i}_{s,1} - \frac{3}{2}\vec{i}_{s,2}$$

[0137] Referring to FIG. 4I, a ninth stator winding connection **400i** is shown that includes first stator winding **402a** and second stator winding **402b**. First stator winding **402a** connects u_{a1} , u_{b1} , v_{a1} , v_{b1} , and w_{a1} , w_{b1} between first inverter **200a** and second inverter **200b**. Second stator winding **402b** connects u_{a2} , u_{b2} , v_{a2} , v_{b2} , and w_{a2} , w_{b2} between third inverter **200c** and the respective phase windings of first stator winding **402a**. Ninth stator winding connection **400i** is a second example of seventh coil group structure **708g**.

[0138] In first stator winding **402a**, the positive terminal of first machine, second winding is connected to the respective phase terminal of first inverter **200a** and the negative terminal of first machine, second winding is connected to the negative terminal of first machine, first winding. The positive terminal of first machine, first winding is connected to the respective phase terminal of second inverter **200b**. The negative terminal of first machine, first winding and of first machine, second winding is also connected to a positive terminal of second machine, first winding and of second machine, second winding. In second stator winding **402b**, the negative terminal of second machine, second winding is connected to a respective phase terminal of third inverter **200c** and the positive terminal of second machine, second winding. The negative terminal of second machine, first winding is connected to first neutral connector **404a**.

[0139] For ninth stator winding connection **400i**,

$$T_c = \begin{bmatrix} 0 & 1 & 0 \\ 1 & 0 & 0 \\ 1 & 1 & 1 \\ 0 & 0 & -1 \end{bmatrix}$$

$$\vec{i}_{a1} = \frac{1}{4}\vec{i}_r - \vec{i}_{s,1}, \vec{i}_{b1} = \frac{1}{4}\vec{i}_r + \vec{i}_{s,1}, \vec{i}_{a2} = \frac{1}{4}\vec{i}_r - \vec{i}_{s,2}, \vec{i}_{b2} = \frac{1}{4}\vec{i}_r + \vec{i}_{s,2}$$

$$\vec{i}_1 = \frac{1}{4}\vec{i}_r + \vec{i}_{s,1}, \vec{i}_2 = \frac{1}{4}\vec{i}_r - \vec{i}_{s,1}, \vec{i}_3 = -\frac{1}{4}\vec{i}_r - \vec{i}_{s,2}$$

[0140] Referring to FIG. 4J, a tenth stator winding connection **400j** is shown that includes first stator winding **402i** and sixth stator winding **402j**. Fifth stator winding **402i** connects u_{a1} , u_{b2} , v_{a1} , v_{b2} , and w_{a1} , w_{b2} between first inverter **200a** and second inverter **200b**. Sixth stator winding **402j** connects u_{a2} , u_{b1} , v_{a2} , v_{b1} , and w_{a2} , w_{b1} between third inverter **200c** and the respective phase windings of fifth stator winding **402i**. Tenth stator winding connection **400j** is a third example of first coil group structure **708a**.

[0141] In first stator winding **402i**, the negative terminal of second machine, second winding is connected to a respective phase terminal of first inverter **200a** and the positive terminal of second machine, second winding is connected to the positive terminal of first machine, first winding and to a respective phase terminal of second inverter **200b**. The negative terminal of first machine, first winding is connected to first neutral connector **404a**. The negative terminal of second machine, second winding is also connected to a negative terminal of first machine, second winding. In second stator winding **402b**, the positive terminal of first machine, second winding is connected to a respective phase terminal of third inverter **200c** and to the positive terminal of second machine, first winding. The negative terminal of second machine, first winding is connected to second neutral connector **404b**.

[0142] For tenth stator winding connection **400j**,

$$T_c = \begin{bmatrix} 1/2 & 3/4 & 1/4 \\ -1/2 & -1/4 & 1/4 \\ 1/2 & 1/4 & 3/4 \\ -1/2 & 1/4 & -1/4 \end{bmatrix}$$

$$\vec{i}_{a1} = \frac{1}{4}\vec{i}_r - \vec{i}_{s,1}, \vec{i}_{b1} = \frac{1}{4}\vec{i}_r + \vec{i}_{s,1}, \vec{i}_{a2} = \frac{1}{4}\vec{i}_r - \vec{i}_{s,2}, \vec{i}_{b2} = \frac{1}{4}\vec{i}_r + \vec{i}_{s,2}$$

$$\vec{i}_1 = -\frac{1}{2}\vec{i}_r - \vec{i}_{s,1} - \vec{i}_{s,2}, \vec{i}_2 = \frac{1}{2}\vec{i}_r - \vec{i}_{s,1} + \vec{i}_{s,2}, \vec{i}_3 = \frac{1}{2}\vec{i}_r + \vec{i}_{s,1} - \vec{i}_{s,2}$$

[0143] Referring to FIG. 6D, a circuit diagram is shown for ninth stator winding connection **400i** in accordance with an illustrative embodiment. Ninth stator winding connection **400i** includes machine voltage source **600** connected across capacitor **602**, first inverter **200a**, second inverter **200b**, and third inverter **200a** between first line **610** and second line **612**. First stator winding **402a** connects u_{a1} , u_{b1} , v_{a1} , v_{b1} , and w_{a1} , w_{b1} between first inverter **200a** and second inverter **200b**. Second stator winding **402b** connects u_{a2} , u_{b2} , v_{a2} , v_{b2} , and w_{a2} , w_{b2} between third inverter **200c** and first stator winding **402a** and first neutral connector **404a**.

[0144] Referring to FIG. 9, a block diagram is shown of a control architecture for a drive **900** with first inverter **200a**, second inverter **200b**, and third inverter **200c** for twin bearingless machine system **100** with any of the coil group structures. A torque command **910**, a first suspension force

command **910s1**, and a second suspension force command **910s2** are provided by outer-loop speed and position regulators (not shown). Torque command **910t** is input to a torque multiplier **902t**, $1/k_t$ to output a torque current \vec{i}_t^* **912t**. First suspension force command **910s1** is input to a first suspension multiplier **902s1**, $1/k_s$ to output a first suspension current \vec{i}_{s1}^* **912s1**. Second suspension force command **910s2** is input to a second suspension multiplier **902s2**, $1/k_s$ to output a second suspension current \vec{i}_{s2}^* **912s2**.

[0145] Torque current \vec{i}_t^* **912t** is summed with a negative of a calculated torque current \vec{i}_t **914t** using a torque summer **904t** and the summed current is input to a current regulator **T 906t**. First suspension force current \vec{i}_{s1}^* **912s1** is summed with a negative of a calculated first suspension force current \vec{i}_{s1} **914s1** using a first suspension force summer **904s1** and the summed current is input to a current regulator **S1 906s1**. Second suspension force current \vec{i}_{s2}^* **912s2** is summed with a negative of a calculated second suspension force current \vec{i}_{s2} **914s2** using a second suspension force summer **904s2** and the summed current is input to a current regulator **S2 906s2**.

[0146] A torque voltage \vec{v}_t^* **916t** is output from current regulator **T 906t** and input to inverter voltage vector calculator **918** based on the coil group structure. A first suspension force voltage \vec{v}_{s1}^* **916s1** is output from current regulator **S1 906s1** and input to inverter voltage vector calculator **918** based on the coil group structure. A second suspension force voltage \vec{v}_{s2}^* **916s2** is output from current regulator **S2 906s2** and input to inverter voltage vector calculator **918** based on the coil group structure.

[0147] A first inverter voltage \vec{v}_1^* **919a** is output from inverter voltage vector calculator **918** and provides the first voltage source **302a** to first inverter **200a**. A second inverter voltage \vec{v}_2^* **919b** is output from inverter voltage vector calculator **918** and provides the second voltage source **302b** to second inverter **200b**. A third inverter voltage \vec{v}_3^* **919c** is output from inverter voltage vector calculator **918** and provides the third voltage source **302c** to third inverter **200c**.

[0148] A first inverter current \vec{i}_1 **920a** is output from first inverter **200a** and provided to first bearingless machine **200a** and second bearingless machine **200b** and input to current calculator **908**. A second inverter current \vec{i}_2 **920b** is output from second inverter **200b** and provided to first bearingless machine **200a** and input to current calculator **908**. A third inverter current \vec{i}_3 **920c** is output from third inverter **200c** and provided to second bearingless machine **200b** and input to current calculator **908**.

[0149] Control current commands are obtained using $\vec{T} = T_d + j\tau = \vec{k}_t \vec{i}_t$ and $\vec{F} = F_x + jF_y = \vec{k}_s \vec{i}_s$ and provided to each respective current regulator to determine the torque and suspension voltages, \vec{v}_t^* , \vec{v}_{s1}^* , \vec{v}_{s2}^* . Inverter voltage vector calculator **918** converts the control voltages to inverter voltage commands using the appropriate relationship for each coil group structure. The inverter currents, \vec{i}_1 , \vec{i}_2 , \vec{i}_3 and position of shaft **102** are measured for control

feedback, with current calculator **908** converting these measurements to control variables using equations (1) and (2) above.

[0150] Differential equations governing the inverter voltage and current space vectors can be derived from a respective space vector diagram. For example, the differential equations below are defined for second space-vector diagram **500** and have been simplified by introducing control voltage space vectors \vec{v}_t , \vec{v}_{s1} , \vec{v}_{s2} that each depend upon only a single control current and are a linear combination of the inverter terminal voltages, \vec{v}_1 , \vec{v}_2 , \vec{v}_3 .

$$\begin{aligned}\vec{v}_t &= \vec{v}_1 - 2\vec{v}_m = \frac{R}{2}\vec{i}_t + \frac{L+M}{2}\frac{d}{dt}\vec{i}_t \\ \vec{v}_{s1} &= \frac{1}{2}\vec{v}_1 - \vec{v}_2 = R\vec{i}_{s1} + (L-M)\frac{d}{dt}\vec{i}_{s1} \\ \vec{v}_{s2} &= \frac{1}{2}\vec{v}_1 - \vec{v}_3 = R\vec{i}_{s2} + (L-M)\frac{d}{dt}\vec{i}_{s2}\end{aligned}$$

[0151] As another example, the differential equations below are defined for ninth stator winding connection **400i**.

$$\begin{aligned}\vec{v}_t &= \vec{v}_1 + \vec{v}_2 - \vec{v}_3 - 4\vec{v}_m = R\vec{i}_t + (L+M)\frac{d}{dt}\vec{i}_t \\ \vec{v}_{s1} &= \frac{\vec{v}_1 - \vec{v}_2}{2} = R\vec{i}_{s1} + (L-M)\frac{d}{dt}\vec{i}_{s1} \\ \vec{v}_{s2} &= -\frac{\vec{v}_3}{2} = R\vec{i}_{s2} + (L-M)\frac{d}{dt}\vec{i}_{s2}\end{aligned}$$

[0152] Each of these expressions are conveniently in the form of an equivalent RL load

$$\vec{V} = R_{eq}\vec{i} + L_{eq}\frac{d}{dt}\vec{i}.$$

The design of current regulation for this class of load is a well-studied problem, with solutions including synchronous frame proportional-integral (PI) regulators and a complex vector current regulator.

[0153] Referring to FIG. 10, a circuit diagram is shown for first stator winding connection **400a** with three direct current voltage sources in accordance with an illustrative embodiment. A first machine voltage source **600a** is connected across a first capacitor **602a**, and first inverter **200a** between a first, first line **610a** and a first, second line **612a**. A second machine voltage source **600b** is connected across a second capacitor **602b**, and second inverter **200b** between a second, first line **610b** and a second, second line **612b**. A third machine voltage source **600c** is connected across a third capacitor **602c**, and third inverter **200c** between a third, first line **610c** and a third, second line **612c**. Each of first inverter **200a**, second inverter **200b**, and third inverter **200c** has their own isolated DC voltage source. While the shared DC voltage approach, for example, of FIG. 6A has the obvious advantage of requiring only a single DC voltage source (reduces cost), this comes with several drawbacks. The shared DC source makes it possible for zero-sequence (or "circulating") currents to flow between the inverters, which can lead to excessive losses in the machine. For this reason,

the implementation of FIG. 6A may use zero-sequence current regulation for two of the three inverters (and thereby three current sensors, instead of two current sensors, for these inverters). This also limits the use of modulation techniques to those that have a constant common mode voltage, preventing use of the space vector modulation (SVM) technique meaning that each inverter is only able to utilize half of the DC source voltage (as opposed to

$$\frac{1}{\sqrt{3}} V_{DC}$$

for SVM).

[0154] When each inverter has its own DC voltage source as in FIG. 10, there is no path for zero-sequence currents to flow. As a result, SVM can be used to increase the DC bus voltage utilization. Furthermore, by employing independent DC voltages, the system is more adaptable in terms of selecting alternative DC voltage sources and switches with different voltage ratings, thereby lowering system costs. In high back-EMF machines, this can be particularly advantageous for second inverter 200b and third inverter 200c, which are exposed to half the back-EMF of first inverter 200a. In addition to these two configurations, an intermediate option is also possible where two inverters share a DC source while a third inverter does not. A particularly compelling option for this drive is to have second inverter 200b and third inverter 200c share a DC link, since these inverters are exposed to the same magnitude of back-EMF and presumably have a very low power requirement as they only provide suspension current. Further improvements are possible, such as providing the shared DC link of second inverter 200b and third inverter 200c with a floating capacitor, where power is drawn through the machine windings.

[0155] Experiment results were generated based on the circuit represented by second space-vector diagram 500 and were compared to the standard twin parallel DPNV structure. The results show that the circuit represented by second space-vector diagram 500 can actuate the same torque and suspension force as the standard twin parallel DPNV structure. The hardware setup consisted of 1) a drive composed of standard three-phase inverters with SiC MOSFETs switched at 100 kilohertz; 2) a 4× three-phase resistor-inductive load in place of a bearingless motor so that force and torque commands can be issued without concern for dynamics introduced by the shaft position controller; and 3) L=1.5 millihenries (mH), M=0 mH, R=1 ohm. Discrete time complex vector current regulators (CVCs) were implemented.

[0156] Referring to FIG. 14A, torque currents generated using the circuit represented by second space-vector diagram 500 are shown in accordance with an illustrative embodiment. A first curve 1400 shows i_t^{*q} , a second curve 1402 shows i_t^{*d} , a third curve 1404 shows i_t^d , and a fourth curve 1406 shows i_t^q .

[0157] Referring to FIG. 14B, first suspension force currents generated using the circuit represented by second space-vector diagram 500 are shown in accordance with an illustrative embodiment. A first curve 1410 shows i_{s1}^{*d} , a second curve 1412 shows i_{s1}^{*q} , a third curve 1414 shows i_{s1}^d , and a fourth curve 1416 shows i_{s1}^q .

[0158] Referring to FIG. 14C, second suspension force currents generated using the circuit represented by second space-vector diagram 500 are shown in accordance with an illustrative embodiment. A first curve 1420 shows i_{s2}^{*d} , a second curve 1422 shows i_{s2}^{*q} , a third curve 1424 shows i_{s2}^d , and a fourth curve 1426 shows i_{s2}^q . The results of FIGS. 14A-14C demonstrate that the circuit represented by second space-vector diagram 500 independently actuates torque and suspension force for the twin bearingless machine with first order responses when PI-based CVCs are used.

[0159] Referring to FIG. 15A, phase currents generated using the circuit represented by second space-vector diagram 500 are shown in accordance with an illustrative embodiment. A first curve 1500 shows i_{ua1} , a second curve 1502 shows i_{ub1} . Referring to FIG. 15B, output inverter currents generated using the circuit represented by second space-vector diagram 500 are shown in accordance with an illustrative embodiment. A third curve 1504 shows i_{u1} , a fourth curve 1506 shows i_{u2} , and a fifth curve 1508 shows i_{u3} .

[0160] Referring to FIG. 15C, phase currents generated the standard twin parallel DPNV structure are shown in accordance with an illustrative embodiment. A first curve 1510 shows i_{ua1} , a second curve 1512 shows i_{ub1} . Referring to FIG. 15D, output inverter currents generated using the standard twin parallel DPNV structure are shown in accordance with an illustrative embodiment. A third curve 1514 shows i_{u1} , a fourth curve 1516 shows i_{u2} , a fifth curve 1518 shows i_{u3} , and a sixth curve 1520 shows i_{u4} .

[0161] FIGS. 15A-15D present oscilloscope measurements of current in the coil group 1 (I_{a1} and I_{b1}) and in the u-phase terminal of inverters I_{un} , n=1, 2, 3, 4. By commanding identical torque and suspension current references, both implementations drive identical machine phase currents (identical actuation of the machine is achieved), but different inverter terminal currents as inverters are connected in different manners. Therefore, the experimental results prove that the circuit represented by second space-vector diagram 500 is capable of actuating a machine with identical torque and suspension forces independently as it is driven by a twin parallel DPNV configuration.

[0162] Power electronic implementation concepts for any of the coil group structures summarized in FIGS. 7A-7G reduce the number of current sensors required by two to six (depending on the implementation) as compared to the conventional four inverter drive without sacrificing the ability to independently actuate torque and suspension force. By reducing the bearingless machine system complexity and cost, twin bearingless machine system 100 has the potential to enable magnetic levitation to disrupt the large landscape of cost sensitive industrial applications, such as HVAC compressors and wastewater aeration equipment.

[0163] As used herein, the term "mount" includes join, unite, connect, couple, associate, insert, hang, hold, affix, attach, fasten, bind, paste, secure, hinge, bolt, screw, rivet, solder, weld, glue, form over, form in, layer, mold, rest on, rest against, abut, and other like terms. The phrases "mounted on", "mounted to", and equivalent phrases indicate any interior or exterior portion of the element referenced. These phrases also encompass direct mounting (in which the referenced elements are in direct contact) and indirect mounting (in which the referenced elements are not in direct contact, but are connected through an intermediate element) unless specified otherwise. Elements referenced as

mounted to each other herein may further be integrally formed together, for example, using a molding or thermoforming process as understood by a person of skill in the art. As a result, elements described herein as being mounted to each other need not be discrete structural elements unless specified otherwise. The elements may be mounted permanently, removably, or releasably unless specified otherwise.

[0164] Use of directional terms, such as top, bottom, right, left, front, back, upper, lower, horizontal, vertical, behind, etc. are merely intended to facilitate reference to the various surfaces of the described structures relative to the orientations introduced in the drawings and are not intended to be limiting in any manner unless otherwise indicated.

[0165] As used in this disclosure, the term “connect” includes join, unite, mount, couple, associate, insert, hang, hold, affix, attach, fasten, bind, paste, secure, bolt, screw, rivet, pin, nail, clasp, clamp, cement, fuse, solder, weld, glue, form over, slide together, layer, and other like terms. The phrases “connected on” and “connected to” include any interior or exterior portion of the element referenced. Elements referenced as connected to each other herein may further be integrally formed together. As a result, elements described herein as being connected to each other need not be discrete structural elements. The elements may be connected permanently, removably, or releasably.

[0166] The word “illustrative” is used herein to mean serving as an example, instance, or illustration. Any aspect or design described herein as “illustrative” is not necessarily to be construed as preferred or advantageous over other aspects or designs. Further, for the purposes of this disclosure and unless otherwise specified, “a” or “an” means “one or more”. Still further, using “and” or “or” in the detailed description is intended to include “and/or” unless specifically indicated otherwise.

[0167] The foregoing description of illustrative embodiments of the disclosed subject matter has been presented for purposes of illustration and of description. It is not intended to be exhaustive or to limit the disclosed subject matter to the precise form disclosed, and modifications and variations are possible in light of the above teachings or may be acquired from practice of the disclosed subject matter. The embodiments were chosen and described in order to explain the principles of the disclosed subject matter and as practical applications of the disclosed subject matter to enable one skilled in the art to utilize the disclosed subject matter in various embodiments and with various modifications as suited to the particular use contemplated. It is intended that the scope of the disclosed subject matter be defined by the claims appended hereto and their equivalents.

What is claimed is:

1. A bearingless electrical machine system comprising:

a shaft;

a first rotor mounted to rotate with the shaft;

a first stator, wherein the first stator is mounted on a side of the first rotor separated by a first air gap between a surface of the first rotor and a surface of the first stator;

a second rotor mounted to rotate with the shaft;

a second stator, wherein the second stator is mounted on a side of the second rotor separated by a second air gap between a surface of the second rotor and a surface of the second stator;

a first, first-phase coil and a second, first-phase coil of a first stator winding wound about the first stator, wherein the first stator winding is configured to provide

a torque and a suspension force relative to the shaft when current is provided to the first stator winding;

a first, second-phase coil and a second, second-phase coil of a second stator winding wound about the first stator, wherein the second stator winding is configured to provide the torque and the suspension force relative to the shaft when current is provided to the second stator winding;

a first, third-phase coil and a second, third-phase coil of a third stator winding wound about the first stator, wherein the third stator winding is configured to provide the torque and the suspension force relative to the shaft when current is provided to the third stator winding;

a first, first-phase coil and a second, first-phase coil of a fourth stator winding wound about the second stator, wherein the fourth stator winding is configured to provide the torque and the suspension force relative to the shaft when current is provided to the fourth stator winding;

a first, second-phase coil and a second, second-phase coil of a fifth stator winding wound about the second stator, wherein the fifth stator winding is configured to provide the torque and the suspension force relative to the shaft when current is provided to the fifth stator winding;

a first, third-phase coil and a second, third-phase coil of a sixth stator winding wound about the second stator, wherein the sixth stator winding is configured to provide the torque and the suspension force relative to the shaft when current is provided to the sixth stator winding; and

an inverter drive system consisting of only a first inverter, a second inverter, and a third inverter, wherein each inverter of the inverter drive system comprises a first connection for a first-phase, a second connection for a second-phase, and a third connection for a third-phase, wherein each first-phase coil is connected to the first connection of the first inverter, the second inverter, or the third inverter,

wherein each second-phase coil is connected to the second connection of the first inverter, the second inverter, or the third inverter,

wherein each third-phase coil is connected to the third connection of the first inverter, the second inverter, or the third inverter.

2. The bearingless electrical machine system of claim 1, wherein the first, first-phase coil of the first stator winding is connected in series with the second, first-phase coil of the first stator winding, with the first, first-phase coil of the fourth stator winding, and with the second, first-phase coil of the fourth stator winding.

3. The bearingless electrical machine system of claim 2, wherein the first inverter is connected between the first, first-phase coil of the first stator winding and the second, first-phase coil of the first stator winding, wherein the second inverter is connected between the second, first-phase coil of the first stator winding and the first, first-phase coil of the fourth stator winding, wherein the third inverter is connected between the first, first-phase coil of the fourth stator winding and the second, first-phase coil of the fourth stator winding.

4. The bearingless electrical machine system of claim 2, wherein the first inverter is connected to a first end of the first, first-phase coil of the first stator winding, wherein the

phase coil of the first stator winding, the second, first-phase coil of the first stator winding, and the first, first-phase coil of the fourth stator winding.

17. The bearingless electrical machine system of claim **16**, wherein the first inverter is connected to the first, first-phase coil of the fourth stator winding, wherein the second inverter is connected to the second, first-phase coil of the fourth stator winding, wherein the third inverter is connected to the first, first-phase coil of the first stator winding or the second, first-phase coil of the first stator winding.

18. The bearingless electrical machine system of claim **1**, wherein the first, first-phase coil of the first stator winding is connected in series with the second, first-phase coil of the first stator winding and with the first, first-phase coil of the fourth stator winding, wherein the second, first-phase coil of the first stator winding is connected in series with the second, first-phase coil of the fourth stator winding.

19. The bearingless electrical machine system of claim **1**, wherein the first, first-phase coil of the first stator winding is connected in series with the second, first-phase coil of the first stator winding, wherein the first, first-phase coil of the first stator winding is connected in series with the first, first-phase coil of the fourth stator winding, wherein the second, first-phase coil of the fourth stator winding is islanded from the first, first-phase coil of the first stator winding, the second, first-phase coil of the first stator winding, and the first, first-phase coil of the fourth stator winding.

20. The bearingless electrical machine system of claim **1**, wherein the first, first-phase coil of the first stator winding is connected in series with the second, first-phase coil of the first stator winding, wherein the first, first-phase coil of the fourth stator winding and the second, first-phase coil of the fourth stator winding are connected to a node between the first, first-phase coil of the first stator winding and the second, first-phase coil of the first stator winding.

* * * * *